

OPERATOR'S MANUAL

LAUNDRY UNIT, TRAILER
MOUNTED, MODEL M85
NSN 3510-01-222-9301

This copy is a reprint which includes current pages from Changes 1 and 2.

TABLE OF
CONTENTS
PAGE 1

HOW TO USE
THIS MANUAL
PAGE iii

EQUIPMENT
DESCRIPTION
PAGE 1-3

OPERATING
INSTRUCTIONS
PAGE 2-1

PREVENTIVE MAINTENANCE
CHECKS AND SERVICES
PAGE 2-14

TROUBLESHOOTING
PROCEDURES
PAGE 3-1

ALPHABETICAL
INDEX
PAGE INDEX 1

Approved for public release; distribution is unlimited.

HEADQUARTERS, DEPARTMENT OF THE ARMY

12 FEBRUARY 1988

CHANGE

NO. 2

HEADQUARTERS
DEPARTMENT OF THE ARMY
WASHINGTON, D.C., 22 May 1991

Operator's Manual

**LAUNDRY UNIT, TRAILER MOUNTED,
MODEL M85
NSN 3510-01-222-9301**

Approved for public release; distribution is unlimited.

TM 10-3510-209-10, 12 February 1988 is changed as follows:

1. Remove and insert pages as indicated below. New or changed text material is indicated by a vertical bar in the margin. An illustration change is indicated by a miniature pointing hand.

Remove pages

Insert pages

2-3 and 2-4

2-3 and 2-4

2. Retain this sheet in front of manual for reference purposes.

By Order of the Secretary of the Army:

CARL E. VUONO
General, United States Army
Chief of Staff

Official:

PATRICIA P. HICKERSON
Colonel, United States Army
The Adjutant General

DISTRIBUTION:

To be distributed in accordance with DA Form 12-25E, (qty rqr block no. 4251).

CHANGE }
NO. 1 }

HEADQUARTERS
DEPARTMENT OF THE ARMY
Washington, D.C., 10 May 1989

Operator's Manual

LAUNDRY UNIT, TRAILER MOUNTED,
MODEL M85
NSN 3510-01-222-9301

Approved for public release. Distribution is unlimited.

TM 3510-209-10, dated 12 February 1988, is changed as follows:

1. Remove and insert pages as indicated below. New or changed text material is indicated by a vertical bar in the margin. An illustration change is indicated by a miniature pointing hand.

Remove pages	Insert pages
i and ii	i and ii
1-0 through 1-6	1-0 through 1-6
2-1 and 2-2	2-1 and 2-2
2-7 through 2-12	2-7 through 2-12
2-17 and 2-18	2-17 and 2-18
2-25 through 2-40	2-25 through 2-40
	2-40.1/2-40.2
2-41 through 2-44	2-41 through 2-44
2-47 through 2-54	2-47 through 2-54
	2-54.1/2-54.2
2-67 through 2-70	2-67 through 2-70
----	2-70.1 and 2-70.2
2-71 through 2-78	2-71 through 2-78
3-3 and 3-4	3-3 and 3-4
B-1 through B-13/B-14	B-1 through B-13/B-14
D-1 and D-2	D-1 and D-2
Index 1 and Index 2	Index 1 and Index 2

2. Retain this sheet in front of manual for reference purposes.

By Order of the Secretary of the Army:

CARL E. VUONO
General, United States Army
Chief of Staff

Official:

WILLIAM J. MEEHAN, II
Brigadier General, United States Army
The Adjutant General

DISTRIBUTION:

To be distributed in accordance with DA Form 12-25A, Operator's Maintenance requirements for Laundry Unit, Single Trailer Mounted, with Canvas Cover, Type M532.

WARNING

CARBON MONOXIDE (EXHAUST GAS) CAN KILL YOU

Carbon monoxide is without color or smell, but can kill you. Breathing carbon monoxide produces symptoms of headache, dizziness, loss of muscular control, a sleepy feeling, and coma. Brain damage or death can result from heavy exposure. Carbon monoxide occurs in the exhaust fumes of fuel-burning heaters and internal combustion engines. Carbon monoxide can become dangerously concentrated under conditions of no ventilation.

Precautions must be followed to ensure operator's safety when the laundry unit is in operation.

1. DO NOT operate laundry unit in an enclosed area without proper ventilation.
2. BE ALERT at all times during operating procedures for carbon monoxide poisoning. If exposure is present, IMMEDIATELY evacuate personnel to fresh air.
3. BE AWARE the field protection mask used for nuclear-biological-chemical attack WILL NOT protect you from carbon monoxide poisoning.

THE BEST DEFENSE AGAINST CARBON MONOXIDE POISONING IS GOOD VENTILATION

WARNING

Remove rings, bracelets, wristwatches, and neck chains before working around or on the laundry unit. Jewelry can catch on equipment and cause injury, or may short across an electrical circuit and cause severe burns or electrical shock.

WARNING

BEFORE OPERATION

Do not operate the unit until the ground terminal stud of the engine-generator set has been connected to a suitable ground. Electrical faults in the engine-generator set, load lines, or load equipment can cause death by electrocution from contact with an ungrounded system.

WARNING

DURING OPERATION

Do not make or change electrical connections while the unit is in operation. The voltage generated by the engine-generator can cause death by electrocution. Keep moisture away from the engine-generator and keep the surrounding area dry when operating the unit. Failure to observe this warning may result in death by electrocution. Do not service the unit with fuel while the unit is in operation. Failure to observe this warning may result in serious injury or death to personnel.

WARNING

Turn off power source before disconnecting. High voltage generated by the power source may cause death or severe injury to personnel.

WARNING

Compressed air used for cleaning purposes will not exceed 30 psi (207 kPa). Use only with effective chip-guarding and personal-protective equipment (goggles, shield, gloves, etc.).

WARNING

Do not touch cold metal parts with bare hands. Frostbite can cause permanent injury.

WARNING

Do not direct high-pressure water hose nozzles or steam cleaner nozzles into electrical connections/junction boxes.

TECHNICAL MANUAL
NO. 10-3510-209-10

HEADQUARTERS
DEPARTMENT OF THE ARMY
Washington, D.C. 12 February 1988

OPERATOR'S MANUAL
FOR THE TRAILER-MOUNTED LAUNDRY UNIT
MODEL M85
NSN 3510-01-222-9301

REPORTING ERRORS AND RECOMMENDING IMPROVEMENTS

You can help improve this manual. If you find any mistakes or if you know of a way to improve the procedures, please let us know. Mail your letter, DA Form 2028 (Recommended Changes to Publications and Blank Forms), or DA Form 2028-2 located in the back of this manual direct to: Commander, US Army Troop Support Command, ATTN: AMSTR-MCTS, 4300 Goodfellow Blvd., St. Louis, MO 63120-1798. A reply will be furnished to you.

Approved for public release; distribution is unlimited.

TABLE OF CONTENTS

		<u>Page</u>
	HOW TO USE THIS MANUAL.....	iii
CHAPTER	1. INTRODUCTION	
	Section I. General Information	1-1
	Section II. Equipment Description	1-3
	Section III. Technical Principles of Operation.....	1-9
CHAPTER	2. OPERATING INSTRUCTIONS	
	Section I. Description and Use of Operator's Controls and Indicators.....	2-1
	Section II. Preventive Maintenance Checks and Services (PMCS)	2-14
	Section III. Operation Under Usual Conditions	2-30
	Section IV. Operation Under Unusual Conditions	2-78
CHAPTER	3. MAINTENANCE INSTRUCTIONS	
	Section I. Lubricating Instructions	3-1
	Section II. Troubleshooting Procedures	3-1
	Section III. Maintenance Procedures	3-13

TABLE OF CONTENTS (CONT)

			<u>Page</u>
APPENDIX	A.	REFERENCES	A-1
APPENDIX	B.	COMPONENTS OF END ITEM AND BASIC ISSUE ITEMS LISTS	
	Section I.	Introduction	B-1
	Section II.	Components of End Item.....	B-3
	Section III.	Basic Issue Items	B-7
APPENDIX	C.	EXPENDABLE/DURABLE SUPPLIES AND MATERIALS LIST	C-1
APPENDIX	D.	ADDITIONAL AUTHORIZATION LIST (AAL)	D-1
ALPHABETICAL INDEX		INDEX 1

HOW TO USE THIS MANUAL

This manual (TM 10-3510-209-10) is designed to help you operate and maintain the model M85 trailer-mounted laundry unit. Listed below are some special features which have been put in to help you locate and use the information need.

A front cover Table of Contents is provided, giving you a quick reference to chapters and sections that you will be using often.

Each section begins with an index listing each paragraph heading.

Subject headings and certain other essential information are printed in bold type to make them more visible.

FOLLOW THESE GUIDELINES WHEN YOU USE THIS MANUAL

Read through this manual and become familiar with the instructions before attempting to operate the laundry unit.

Read all warnings and cautions before performing any procedures.

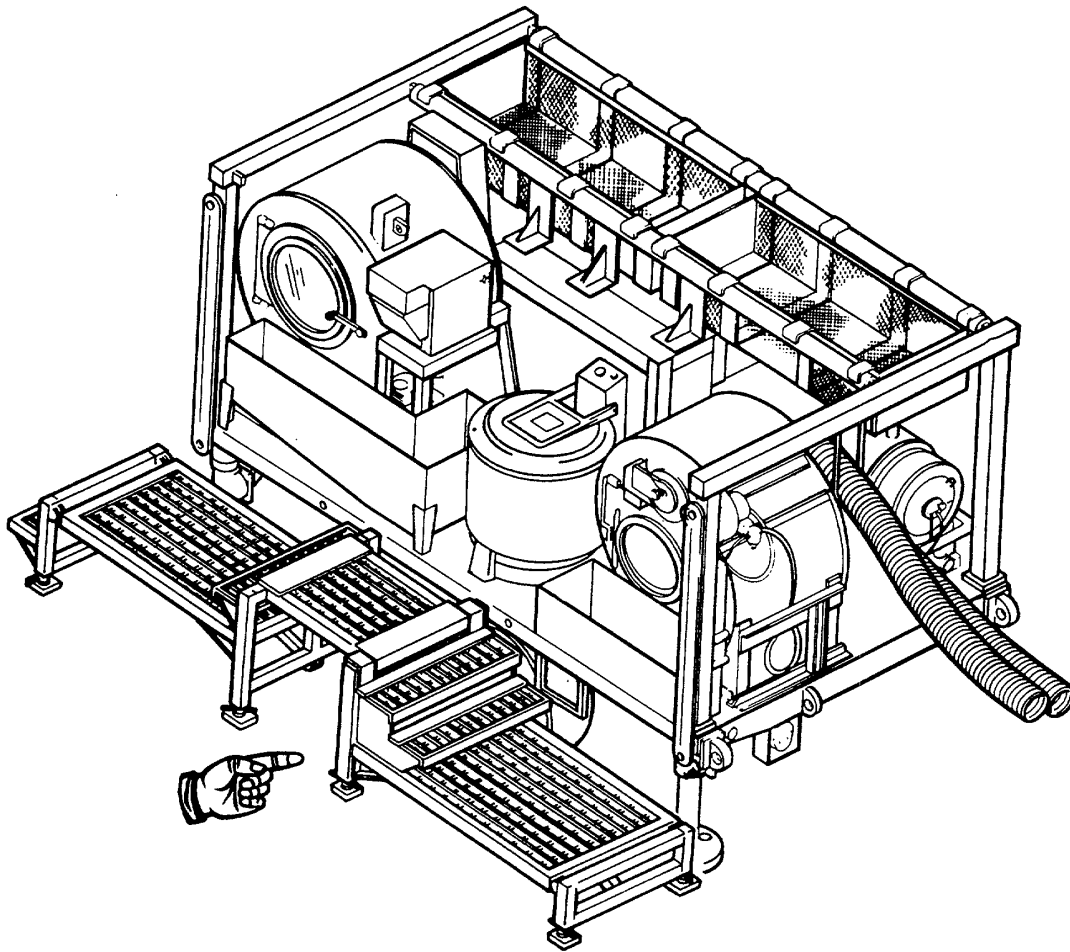

FIGURE 1-0. Trailer-mounted laundry unit M85.

1-0 Change 1

CHAPTER 1
INTRODUCTION

Section I. GENERAL INFORMATION

Para	Title	Page
1-1	Scope	1-1
1-2	Maintenance Forms and Records.....	1-1
1-3	Hand Receipt (HR) Manuals	1-1
1-4	Reporting Equipment Improvement Recommendations (EIR)	1-1
1-5	Warranty Information	1-1
1-6	Metric System.....	1-1
1-7	Reference Information	1-2

1-1. SCOPE. This operator's manual describes the operating and operator's maintenance procedures for the M85 trailer-mounted laundry unit.

1-2. MAINTENANCE FORMS AND RECORDS. Department of the Army forms and procedures used for equipment maintenance will be those prescribed by DA PAM 738-750, The Army Maintenance Management System (TAMMS).

1-3. HAND RECEIPT (HR) MANUALS. This manual has a companion document with a TM number followed by -HR (which stands for hand receipt). The TM 10-3510-209-10-HR consists of preprinted hand receipts (DA Form 2062) that list end item-related equipment (i.e., COEI and BII) you must account for. As an aid to property accountability, additional -HR manuals may be requisitioned from the following source in accordance with procedures in chapter 3 of AR 310-2:

The US Army Adjutant General Publications Center
ATTN: AGLD-OD
1655 Woodson Road
St. Louis, MO 63114

1-4. REPORTING EQUIPMENT IMPROVEMENT RECOMMENDATIONS (EIR). If your laundry unit needs improvements, let us know. Send us an EIR. You, the user, are the only one who can tell us what you don't like about your equipment. Let us know why you don't like the design or performance. Put it on an SF 368 (Quality Deficiency Report). Mail it to Commander, US Army Troop Support Command, ATTN: AMSTR-QX, 4300 Goodfellow Blvd., St. Louis, MO 63120-1798. We'll send you a reply.

1-5. WARRANTY INFORMATION. The laundry unit components are warranted by the manufacturers for 12 months. The warranty starts on the date found in block 23, DA Form 2408-9, in the logbook. Report defects in material or workmanship to your supervisor, who will take appropriate action through your organizational maintenance shop.

1-6. METRIC SYSTEM. The equipment described herein contains metric components and requires metric common and special tools; therefore, metric units in addition to English units will be used throughout this publication. See reference information (para 1-7b) for abbreviations. An English-to-metric conversion table is included as the last page of this manual, inside the back cover.

1-7. REFERENCE INFORMATION. This paragraph includes the nomenclature cross- reference list, list of abbreviations, and an explanation of terms (glossary) used in this manual.

a. Nomenclature Cross-Reference List.

<u>Common Name</u>	<u>Official Nomenclature</u>
Deleted	
Compressor	Compressor, Air
Controller	Control, Programmer
Control Stand.....	Controller, Stand
Dryer.....	Drying Tumbler, Laundry
Dryer Bin	Bin Assembly, Dryer
Extractor	Extractor, Laundry
Drain Bin.....	Bin, Pre-Extraction
Generator Set	Generator Set, Diesel Engine Driven, 10 kW, 60 Hz
Laundry Unit	Laundry Unit, Trailer-Mounted
Platform.....	Platform, Work
Trailer	Trailer, Cargo, 5-Ton, M10-61E1
Washer	Washing Machine, Laundry, Open-End Type
Water Heater	Heater, Water, Liquid Fuel: M-80

b. Abbreviations.

BDU	Battle Dress Uniform
BII	Basic Issue Items List
CAGE	Commercial and Government Entity
COEI	Components of End Item
EIR	Equipment Improvement Recommendation
gpm	Gallons per Minute
Hz	Hertz
hp	Horsepower
kg	Kilogram(s)
kPa	Kilopascal(s)
m	Meter(s)
qt	Quart
rpm	Revolutions per Minute
Vac	Volts Alternating Current
W	Watt(s)
wt	Weight

c. Glossary.

Extract- To remove most of the water from a wet wash load by spinning load in a perforated drum.

Hertz- Cycles per second of electrical current.

Tumbler-Horizontal, rotating drum that tosses wash load about and effects more efficient washing or drying.

Section II. EQUIPMENT DESCRIPTION

Para	Title	Page
1-8	Equipment Characteristics, Capabilities, and Features.....	1-3
1-9	Location and Description of Major Components.....	1-4
1-10	Equipment Data	1-7

1-8. EQUIPMENT CHARACTERISTICS, CAPABILITIES, AND FEATURES.

a. Purpose. The unit is to be used in the field to provide regular troop units and hospitals with field laundry service.

b. Capabilities. The laundry unit is a self-contained laundry center with the capability of washing and drying 120 pounds (54 kg) of cotton, woolen, and durable press items in a 1-hour period, with two operators.

c. Features. The laundry unit is mounted on an M10-61E1 tandem-wheel trailer. Its mission equipment includes:

- (1) Open end washer
- (2) Extractor
- (3) Dryer
- (4) M-85 water heater
- (5) Water pump
- (6) Air compressor
- (7) 10-kW diesel generator

1-9. LOCATION AND DESCRIPTION OF MAJOR COMPONENTS.

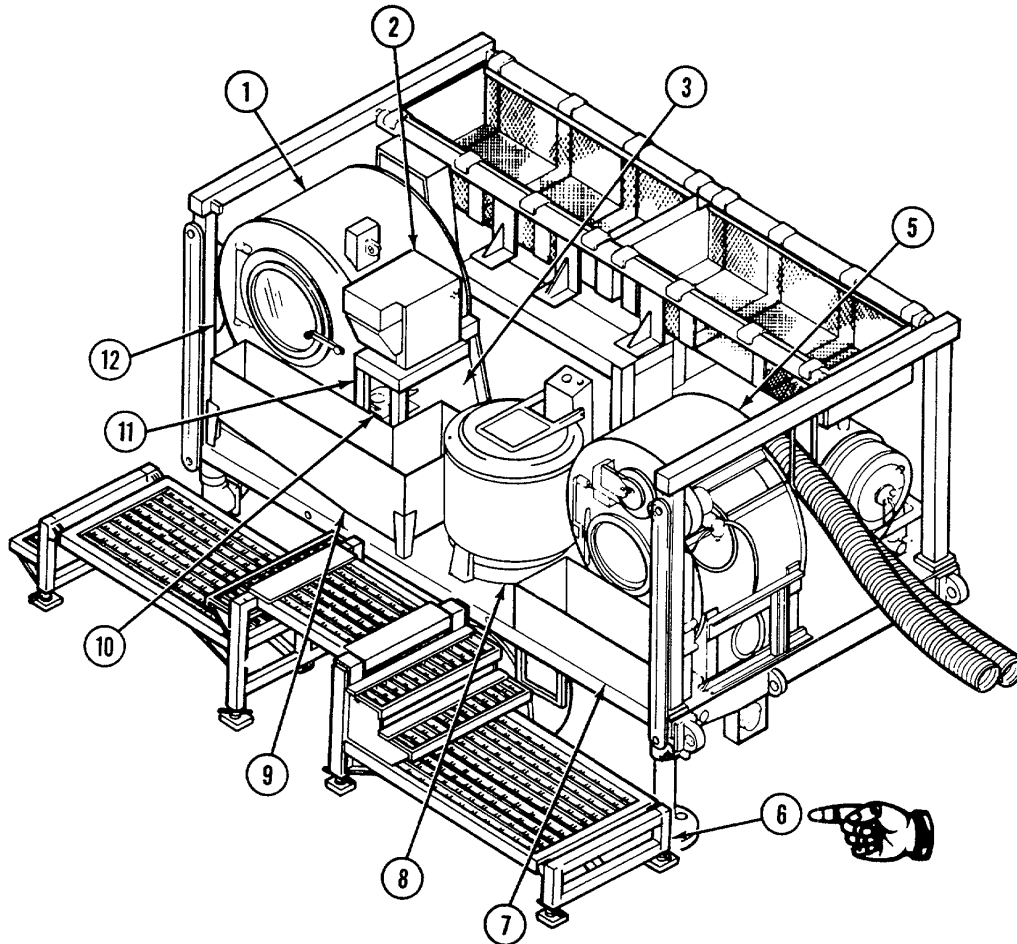

FIGURE 1-1. M85 trailer-mounted laundry unit component location. (Sheet 1 of 2).

1-9. LOCATION AND DESCRIPTION OF MAJOR COMPONENTS. (CONT)

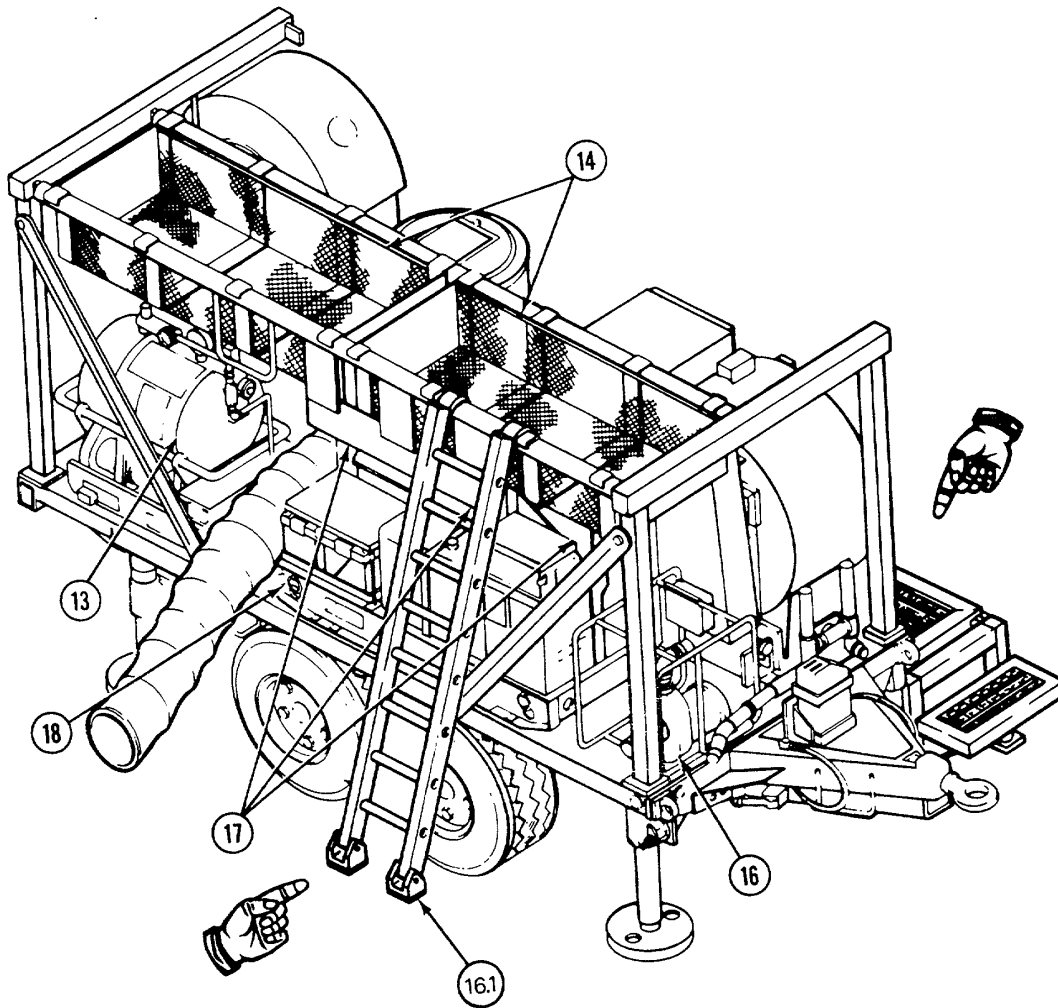

FIGURE 1-1. M85 Trailer Mounted Laundry Unit component location. (Sheet 2 of 2)

1-9. LOCATION AND DESCRIPTION OF MAJOR COMPONENTS. (CONT)

- 1 **WASHER.** Washer (1, FIG. 1-1) is an open-end loader, reversible-type cylinder. The washer washes soiled clothes and linen during the wash cycle.
- 2 **CONTROLLER.** Controller controls the operations of the washer assembly.
- 3 **CIRCUIT BREAKER BOX.** Circuit breaker box is located behind control stand (11) and provides safety cutouts for electrical circuits.
- 4 **Deleted.**
- 5 **DRYER.** Dryer assembly is an open-end, nonreversible-type cylinder. The dryer dries the clothes after they are removed from the extractor.
- 6 **PLATFORM.** Platform provides the operator with a place to stand and walk while operating the laundry unit.
- 7 **DRYER BIN.** Dryer bin provides a holding place for the dry clothes after they are removed from the dryer. During transport, the dryer bin is stored on the right-hand side of the trailer.
- 8 **EXTRACTOR.** Extractor is a heavy-duty, top-loading-type cylinder. It removes excess water from the clothes before they are placed in the dryer.
- 9 **PRE-EXTRACTION BIN.** Pre-extraction bin provides a holding place for the wet clothes before they are placed in the extractor.
- 10 **AIR COMPRESSOR.** Air compressor provides air pressure for the operation of the water valves.
- 11 **CONTROL STAND.** Control stand is the housing for the controller and compressor.
- 12 **FIRE EXTINGUISHER.** Portable fire extinguisher is provided for emergency use in case of fire.
- 13 **WATER HEATER.** Water heater heats incoming water to desired temperatures as needed for the washer.
- 14 **HOSE BASKET ASSEMBLY.** Hose basket assemblies provide storage for hoses, heater ducts, and other equipment.
- 15 **Deleted.**
- 16 **WATER PUMP.** Water pump provides the necessary water needed for the laundry unit.
- 16.1 **LADDER.** Ladder assists operator in reaching hose baskets.
- 17 **SOUND DEADENING PANELS.** Sound deadening panels shield the operator from generator noise.
- 18 **GENERATOR.** Generator provides electrical power to major components of the laundry unit.

1-10. EQUIPMENT DATA.

a. Laundry Unit.

Model number	M85
Length.....	18 ft 2 in. (5.54 m)
Height	7 ft 10 in. (2.39 m)
Width	8 ft (2.44 m)
Weight	12,860 lb (5838 kg)
Power Requirements	Class L, 60 amps, 208/220 V ac, 3-phase
Fuel Requirements.....	Diesel fuel (item 10, app C)

b. Open-End Washer.

Model Number	360 EW/ACJ
Maximum speed.....	33 rpm
Capacity.....	60 lb (27 kg)
Water Pressure Required	10 psi (69 kPa) minimum, 75 psi (517 kPa) maximum
Air Pressure Required	30 psi (207 kPa) minimum, 110 psi (758 kPa) maximum
Volts.....	208 V ac
Phase.....	3
Frequency	60 Hz
Amps	7.6 amps
Power rating.....	1.5 hp (1 119 W)
Motor speed	1725 rpm

c. Extractor.

Maximum speed.....	1725 rpm
Capacity.....	30 lb (14 kg)
Volts.....	208/220 V ac
Phase.....	3
Frequency	60 Hz
Amps	9.3 amps
Power rating.....	3 hp (2 238 W)
Motor speed	1750 rpm

d. Dryer.

(1) Burner Blower and Fuel Pump Motor

Volts.....	208/220 V ac
Phase.....	3
Frequency	60 Hz
Amps	2.1 amps
Power rating.....	1/2 hp (373 W)
Motor speed	3450 rpm

1-10. EQUIPMENT DATA. (CONT)

(2) Tumbler Cylinder Motor

Volts.....	208 V ac
Capacity.....	30 lb (14 kg)
Phase.....	3
Frequency.....	60 Hz
Amps.....	2.1 amps
Power rating.....	1/2 hp (373 W)
Motor speed.....	1725 rpm

(3) Tumbler Exhaust Motor

Volts.....	208 V ac
Phase.....	3
Frequency.....	60 Hz
Amps.....	2.2 amps
Power rating.....	1/2 hp (373 W)
Motor speed.....	1725 rpm

e. Air Compressor.

Volts.....	208 V ac
Phase.....	3
Frequency.....	60 Hz
Amps.....	2.2 amps
Power rating.....	1/2 hp (373 W)
Motor speed.....	1725 rpm

f. Water Heater

Fuel Pump Pressure..... 0 to 150 psi (1 034 kPa)

Burner Blower Fuel Pump Motor

Volts.....	208 V ac
Phase.....	3
Frequency.....	60 Hz
Power rating.....	1/3 hp (249 W)
Motor speed.....	3450 rpm

g. Water Pump.

Type..... Centrifugal, self-priming after initial prime;
 Capacity 18-20 gpm (68-76 liters/minute) at 65-foot (19.8 m) head

1-10. EQUIPMENT DATA. (CONT)

Pump Motor

Volts	208 V ac
Phase.....	3
Frequency.....	60 Hz
Amps	3.1/1.0 amps
Power rating.....	3/4 hp (560 W)
Motor speed.....	3450 rpm

SECTION III. TECHNICAL PRINCIPLES OF OPERATION

Para	Title	Page
1-11	Introduction.....	1-9
1-12	Washer	1-9
1-13	Extractor	1-10
1-14	Dryer	1-10
1-15	Water Heater.....	1-10
1-16	Water Pump	1-10
1-17	Air Compressor.....	1-10
1-18	Generator and Power Distribution Box.....	1-10

1-11. INTRODUCTION. The laundry system consists of seven functional systems:

- a. Washing system
- b. Extracting system
- c. Drying system
- d. Water heating system
- e. Water pumping system
- f. Air compressor system
- g. Generator/power distribution system

1-12. WASHER.

The heavy-duty washer is powered by an externally-mounted motor, drive train, and control unit. The washer is controlled either automatically or manually and has a 60-pound (27 kg) capacity. Two 60-pound (27 kg) loads can be washed per hour in the automatic mode. Automatic operation is provided by a control unit programmable to regulate all functions of the laundry cycle. These functions are the number of washes and rinses, water level, and water temperature. Charts used to operate the controller are pre-punched with standard cycles. Manual operation has a variable wash time of up to 30 minutes.

1-13. EXTRACTOR.

The extractor uses centrifugal force to extract water from the wash load prior to the drying process. It is powered by a 3-hp (2 238 W) motor. The extractor control has a 10-minute variable timer and has a load capacity of 30 pounds (14 kg).

1-14. DRYER.

The heavy-duty dryer is powered by an externally-mounted 1/2 hp (373 W) motor and drive train. It has a capacity of 30 pounds (14 kg) per load, approximately four loads per hour. Controls provide for an adjustable range of 15 minutes for the drying cycle. Air is heated by a fuel-fired air heater mounted on the dryer.

1-15. WATER HEATER.

The water heater heats incoming water for the washer assembly.

1-16. WATER PUMP.

The portable, centrifugal-type water pump is mounted in a carrying frame. The pump is stored on the right front side of the trailer during transport. During use, it is placed near the water source and connected to the facility by a water output hose and power cable. After the initial prime, the pump will deliver 18 to 20 gallons (68 to 76 liters) of water per minute.

1-17. AIR COMPRESSOR.

The air compressor provides air pressure for the operation of washer water intake and drain valves. The adjustable range of compressed air is 20 to 80 psi (138 to 552 kPa).

1-18. GENERATOR AND POWER DISTRIBUTION BOX .

The generator is mounted on the right-hand side of the trailer. Refer to TM 5-6115-585-12 for general description. The laundry unit operates on 60-Hertz, 3-phase, 208 V ac power. An electrical panel provides power distribution from the engine generator to the components of the laundry facility. The panel includes the necessary circuit breakers for powering facility components.

CHAPTER 2
OPERATING INSTRUCTIONS

SECTION I. DESCRIPTION AND USE OF OPERATOR'S CONTROLS AND INDICATORS

Para	Title	Page
2-1	Introduction	2-1
2-2	Location and Use of Controls and Indicators	2-1

2-1. INTRODUCTION.

This section shows the location and describes the use of controls and indicators you will use in operating your equipment.

2-2. LOCATION AND USE OF CONTROLS AND INDICATORS.

- a. You should know the location and proper use of every control and indicator before operating the laundry unit. Use this section to learn or refresh your memory about each control and indicator and how it works.
- b. Refer to TM 5-6115-585-12, Generator Set, Diesel Engine Driven, 10kW, 60 Hz, for generator controls and indicators.
- c. For locations and functions of the controls and indicators on the laundry unit, refer to the following figures.

<u>Controls/Indicators</u>	<u>Figure</u>
Washer System.....	2-1
Dryer System	2-2
Extractor System.....	2-3
Water Heater	2-4
Deleted	
Water Pump.....	2-6
Circuit Breakers	2-7
Compressed Air System.....	2-8

2-2. LOCATION AND USE OF CONTROLS AND INDICATORS. (CON'T)

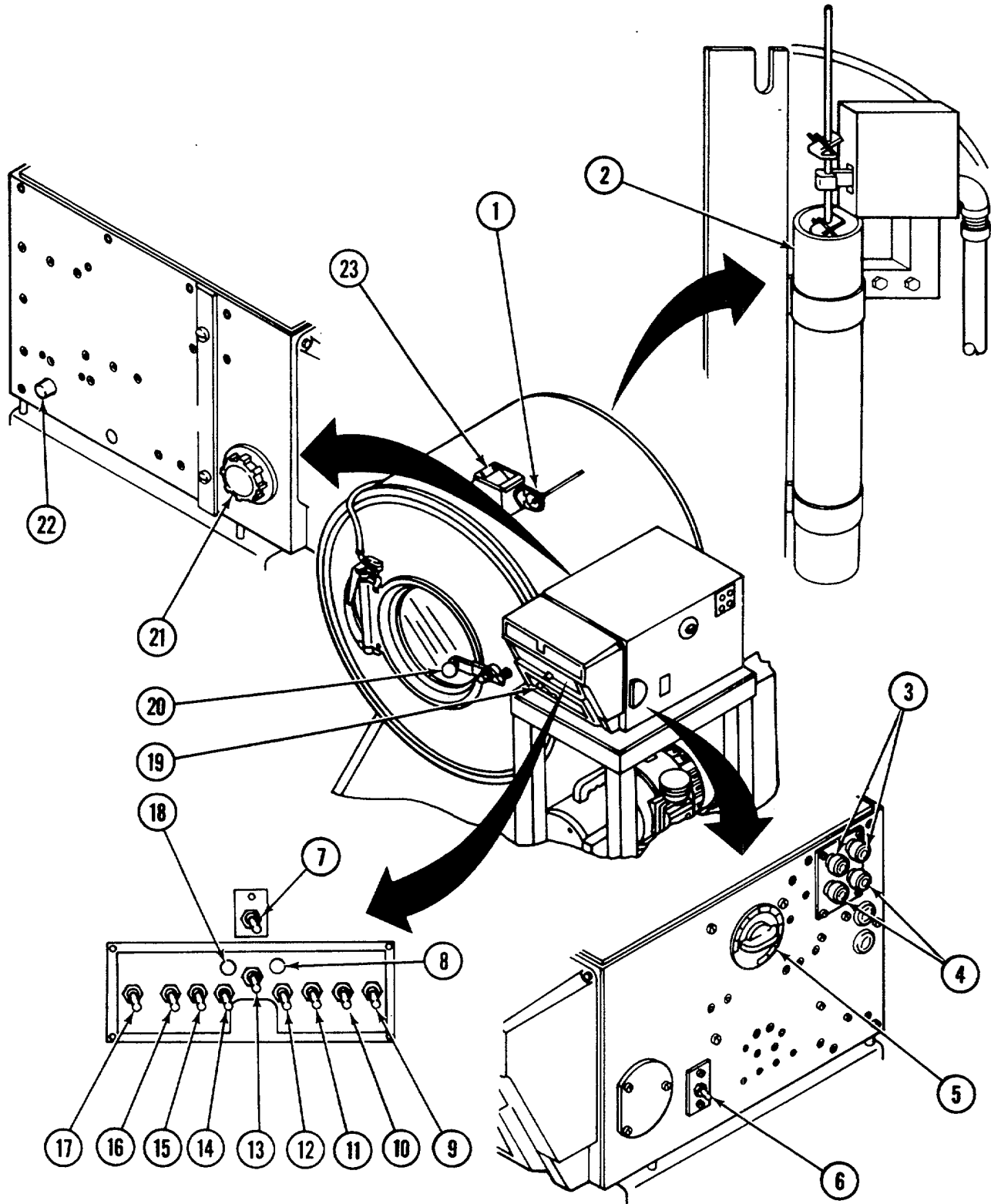

Figure 2-1. Washer system controls and indicators.

2-2. LOCATION AND USE OF CONTROLS AND INDICATORS. (CONT)

Key	Control or Indicator	Function/Use
1	Temperature Gage	Indicates temperature of water coming from water heater
2	Float Level	Controls amount of water allowed inside cylinder
3	1 5-Amp Fuses	Protects the 240 V circuit
4	10-Amp Fuses	Protects the 240 V circuit
5	Timer Control	Controls time of operation during manual operation
6	ENABLED POSITION Switch	Activates signal indicator light during manual operation
7	DRAIN REUSE Switch	Not used (nonfunctional)
8	SIGNAL Indicator Light	Alerts operator that attention is required at the washer controls
9	COLD WATER Switch	Turns cold water valve on/off
10	HOT WATER Switch	Turns hot water valve on/off
11	WATER LEVEL Switch	Selects high and low water levels
12	DRAIN Switch	Opens and closes drain valve
13	SIGNAL Cancel Switch	Cancel signal indicator light
14	CONTROL NO 2 Switch	Not used (nonfunctional)
15	TEMPERATURE NO 1 Switch	Not used (nonfunctional)
16	MOTOR Switch	Turns drive motor on/off
17	MASTER Switch	Turns controller on/off and operates chart drive motor
18	TIMER Indicator Light	Indicates machine is on and cylinder is advancing during automatic operation
19	Interior Light	Indicates to operator that power is on and unit is in operation
20	Door Latch	Provides access to washer drum
21	Control Knob	Manually advances cylinder
22	Reset Button	Resets motor circuit breaker
23	Soap Chute	Allows operator to add supplies during the washing cycle.

2-2. LOCATION AND USE OF CONTROLS AND INDICATORS. (CON'T)

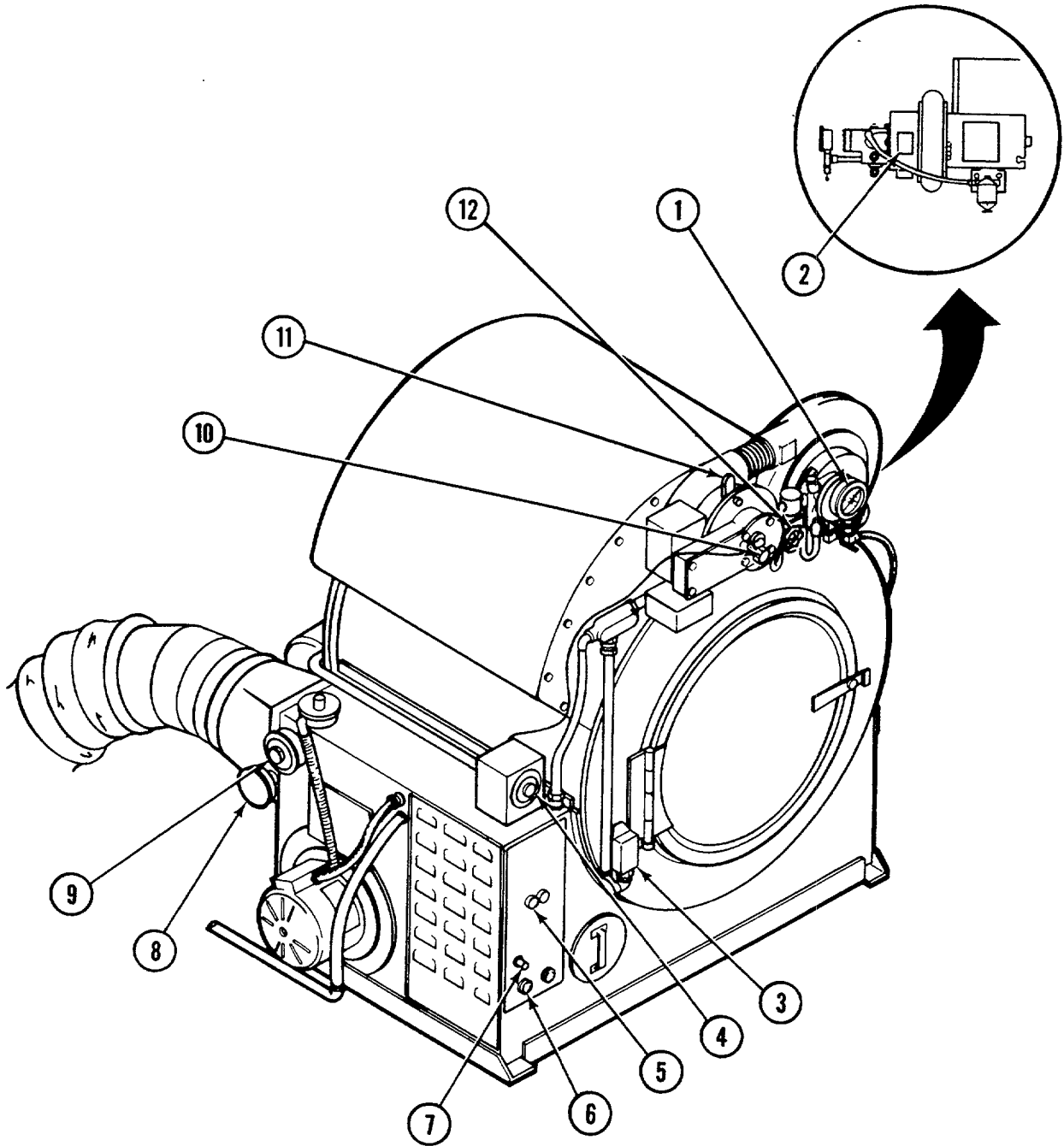

Figure 2-2. Dryer system controls and indicators.

2-2. LOCATION AND USE OF CONTROLS AND INDICATORS. (CONT)

Key	Control or Indicator	Function/Use
1	Fuel Pressure Gage	Indicates pressure of fuel to burner.
2	Burner-Air Intake	Controls amount of air to burner. a. Turned downward, increases air to burner. b. Turned upward, decreases air to burner.
3	Door Limit Switch	Stops tumbler rotation when dryer door is opened.
4	Electric Timer	Controls drying time.
5	Start/Stop Buttons	Starts and stops blower motor and turns ignition on and off.
6	Buzzers	Alerts operator that a safety shutdown has occurred.
7	UV Scanner Indicator light	Gives visual indication that a safety shutdown has occurred.
8	Exhaust Temperature Gage	Indicates temperature of drying air inside tumbler.
9	Temperature Control	Controls temperature inside of tumbler.
10	Tumbler Burner Sight Glass	To observe flame inside the burner.
11	Air Shutter	Allows operator to fine-tune air fuel mixture.
12	Burner Fuel Shutoff Valve	Opens and closes fuel supply to burner.

2-2. LOCATION AND USE OF CONTROLS AND INDICATORS. (CONT)

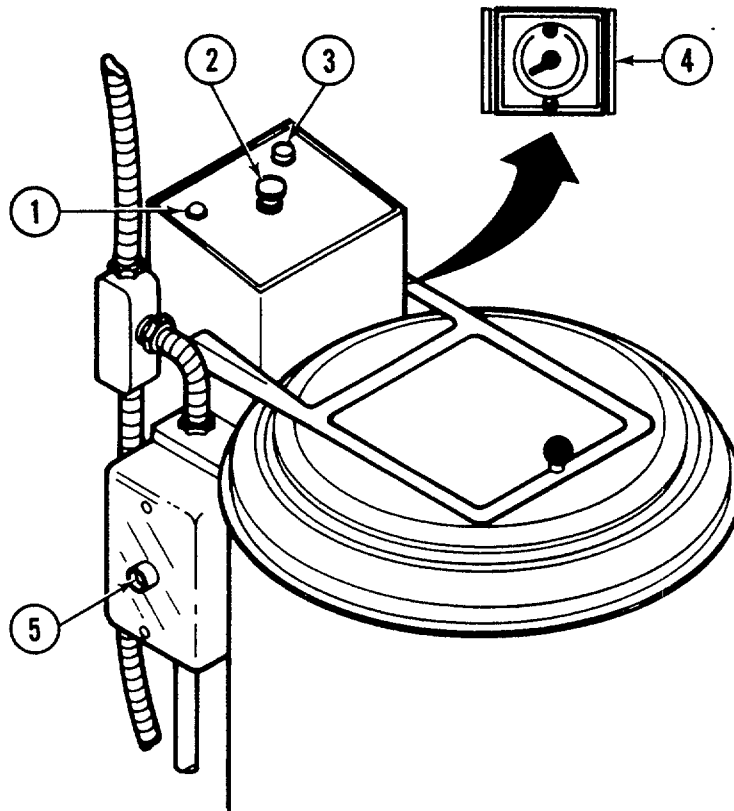

FIGURE 2-3 . Extractor system controls and indicators .

Key	Control or Indicator	Function/Use
1	Lid Lock Indicator	Light indicates that lid is locked in closed position.
2	Emergency Stop	Allows the operator to shut down the extractor.
3	Start Button	Starts the extractor motor.
4	Timer Control	Allows the operator to control extractor times.
5	Reset Button	Resets motor circuit breaker.

2-2. LOCATION AND USE OF CONTROLS AND INDICATORS. (CONT)

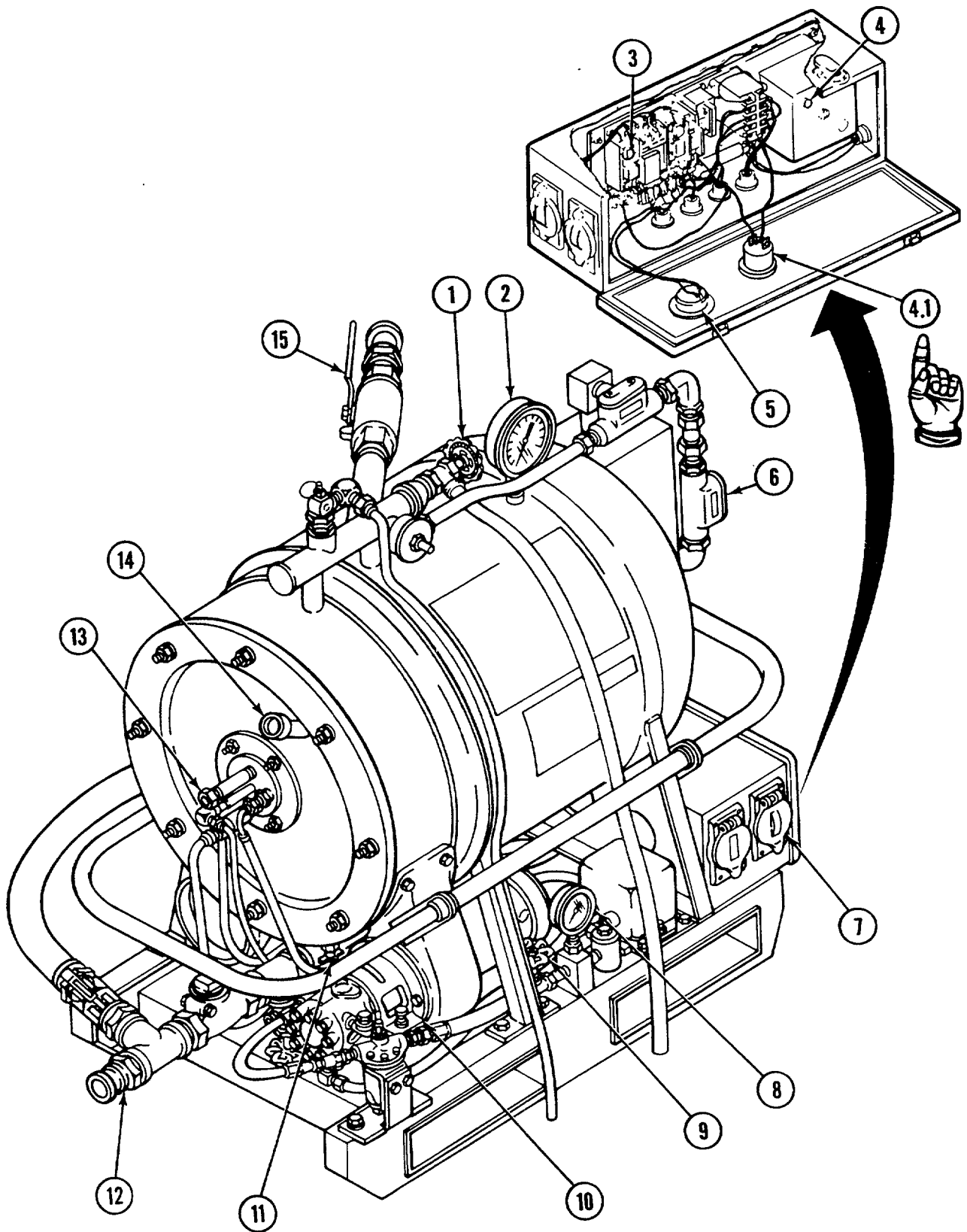

FIGURE 2-4. Water heater system controls and indicators .

2-2. LOCATION AND USE OF CONTROLS AND INDICATORS. (CONT)

Key	Control or Indicator	Function/Use
1	Vent Valve	Allows the operator to bleed air from water heater
2	Water Temperature Gage	Indicates temperature of water being supplied to the washer assembly
3	Motor Contactor Reset	Over current reset devices that break the circuit to the blower motor, if motor input leads are overloaded
4	Flame Safeguard Control	Lockout switch for flame safeguard control Reset system When pressed, resets electrical circuit to allow ignition in water heater combustion chamber
4.1	Buzzer	Alerts the operator that his/her attention is needed at the water heater controls
5	Hour Meter	Indicates length of time that burner has been in operation
6	Water Temperature Control	A calibrated dial to set the desired outlet water temperature between 0° and 250°F (-18 and +121°C) Operates burner to maintain outlet water temperature between 182° and 210°F (83 and 99°C)
7	Load Limit Switch	Single-throw switch used to disconnect power to (Water Heater Switch) motor, ignition transformer, and all electrical controls on water heater
8	Fuel Pressure Gage	Registers pressure of fuel being supplied to burner
9	Manual Fuel Shutoff Valve	Starts and stops flow of fuel to burner <ul style="list-style-type: none"> a. Valve turned clockwise closes valve and stops flow of fuel to burner b. Valve turned counterclockwise opens valve and starts flow of fuel to burner
10	Blower Shutter	Increases or decreases amount of air to burner <ul style="list-style-type: none"> a. Shutter turned downward increases amount of air to burner b. Shutter turned upward decreases amount of air to burner

2-2. LOCATION AND USE OF CONTROLS AND INDICATORS. (CONT)

Key	Control or Indicator	Function/Use
11	Petcock Valve	Allows operator to drain excess fuel from combustion chamber.
12	Drain Valve	Allows operator to drain water from water heater.
13	Burner Spark Sight Glass	Allows the operator to observe ignition spark.
14	Sight Glass Assembly	Allows the operator to observe flame inside burner assembly.
15	Hot Water Output Valve	Controls hot water output from the water heater to the washer.

"All data on page 2-10, including figure 2-5 deleted."

Change 1 2-10

2-2. LOCATION AND USE OF CONTROLS AND INDICATORS. (CONT)

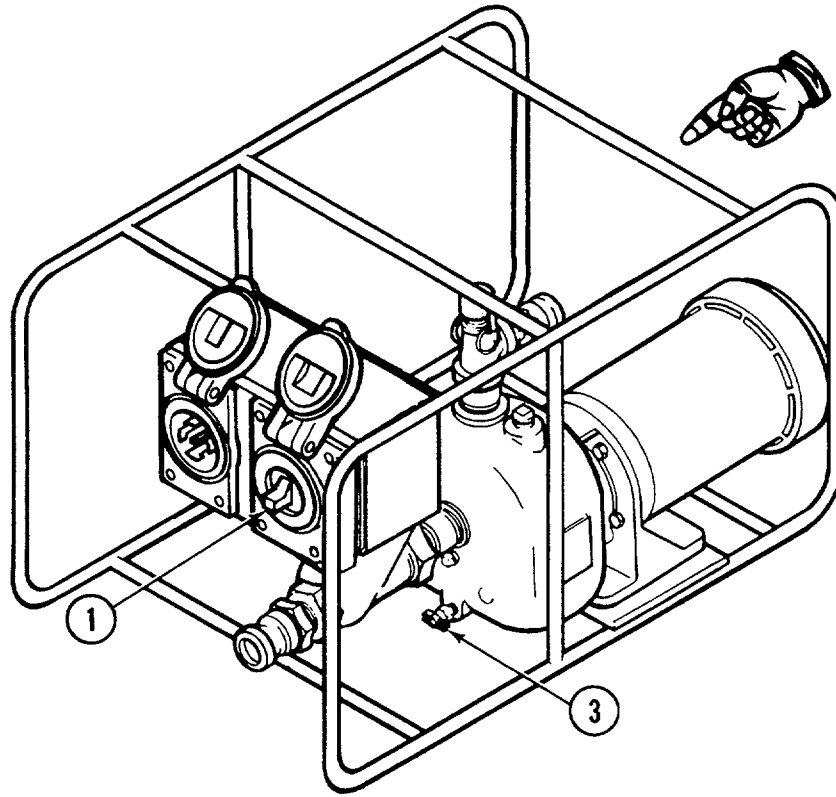

FIGURE 2-6. Water pump system controls and indicators.

Key	Control or Indicator	Function/Use
1	Start Switch	Turns water pump on or off.
2	Deleted	
3	Petcock Valve	Allows the operator to drain water from water pump.

2-2. LOCATION AND USE OF CONTROLS AND INDICATORS. (CONT)

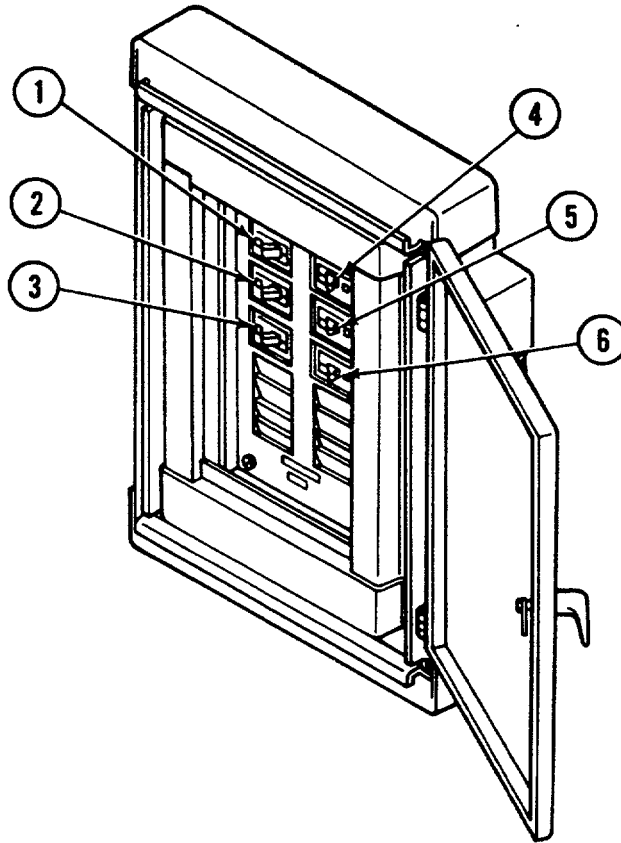

FIGURE 2-7. Circuit breaker system controls and indicators .

Key	Control or Indicator	Function/Use
1	60-Amp Circuit Breaker	Main circuit breaker for the laundry unit.
2	20-Amp Circuit Breaker	Single-throw switch used to disconnect power to the dryer.
3	20-Amp Circuit Breaker	Single-throw switch used to disconnect power to the compressor.
4	20-Amp Circuit Breaker	Single-throw switch used to disconnect power to the washer.
5	20-Amp Circuit Breaker	Single-throw switch used to disconnect power to the water heater.
6	20-Amp Circuit Breaker	Single-throw switch used to disconnect power to the extractor.

2-2. LOCATION AND USE OF CONTROLS AND INDICATORS. (CONT)

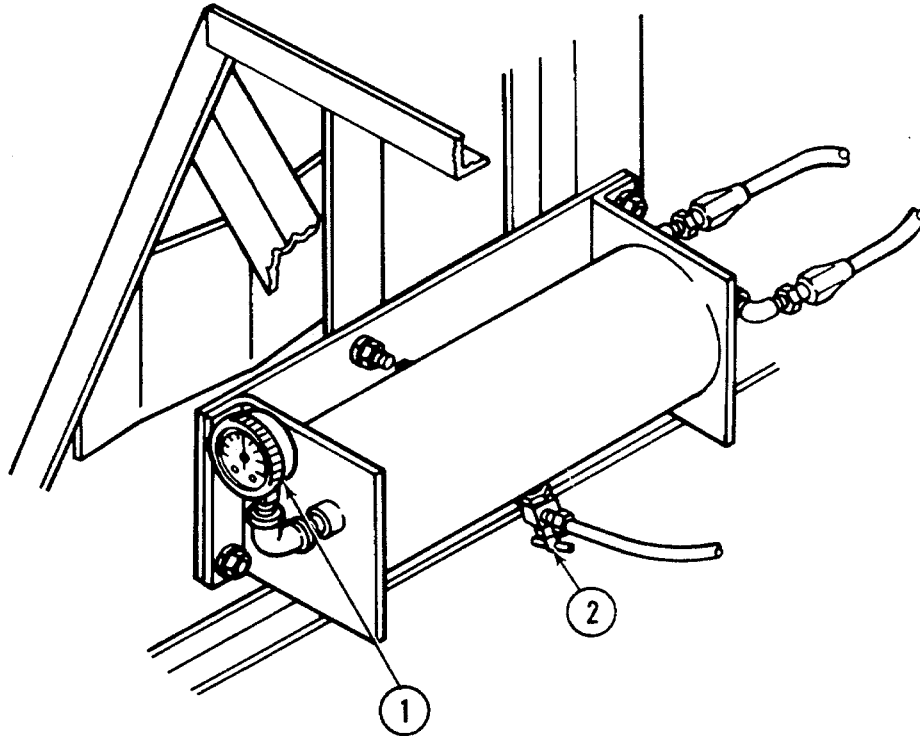

FIGURE 2-8 . Compressed air system controls and indicators .

Key	Control or Indicator	Function/Use
1	Pressure Gage	Indicates pressure inside air tank assembly.
2	Drain Valve	Allows operator to bleed air and water from air tank.

SECTION II. PREVENTIVE MAINTENANCE CHECKS AND SERVICES (PMCS)

Para	Title	Page
2-3	Introduction	2-14
2-4	General Maintenance Procedures.....	2-16
2-5	Operator/Crew Preventive Maintenance Checks and Services Table.....	2-16

2-3. INTRODUCTION.

- a. General. Your preventive Maintenance Checks and Services table lists the inspections and care your equipment requires to keep it in good operating condition.
 - (1) Before you operate - Always keep in mind the CAUTIONS and WARNINGS. Perform your before (B) PMCS.
 - (2) While you operate - Always keep in mind the CAUTIONS and WARNINGS. Perform your during (D) PMCS.
 - (3) After you operate - Be sure to perform your after (A) PMCS.
 - (4) If your equipment fails to operate - If your equipment does not perform as required, refer to chapter 3 under Troubleshooting for possible problems. Report any malfunctions or failures on the proper DA Form 2404, or refer to DA PAM 738-750.

- b. PMCS Columnar Entries.
 - (1) Item number column. This is the order in which you perform checks and services on the laundry unit. The entry in this column will also be used as a source of item numbers for the TM Item Number column on DA Form 2404, Equipment Inspection and Maintenance Worksheet, in recording results of PMCS.
 - (2) Interval column. The Interval column of your PMCS table tells you when to do a certain check or service.
 - (3) Item to be Inspected column. Identification of item to be inspected.
 - (4) Procedures column. The Procedures column of your PMCS table tells you how to do the required checks and services. Carefully follow these instructions. If you do not have the tools, or if the procedure tells you to, have the next higher level of maintenance do the work.

2-3. INTRODUCTION. (CONT)

- (5) Equipment Is Not Ready/Available If column. Entries in this column will be keyed specifically to checks listed in the Procedures column for the purpose of identifying, for the check, the criteria that will cause the equipment to be classified as not ready/available because of inability to perform its primary Combat Mission. An entry in this column will:
 - (a) Identify conditions that make the equipment not ready/available for readiness reporting.
 - (b) Deny use of the equipment until corrective maintenance has been performed.

c. Special Instructions.

- (1) Perform Weekly (W) as well as Before operations PMCS if:
 - (a) You are the assigned operator and have not operated the item since the last weekly.
 - (b) You are operating the item for the first time.
- (2) Leakage definitions for operator/crew PMCS shall be classified as follows:

NOTE

Equipment operation is allowable with minor leakage (Class I or II). Of course, you must consider the fluid capacity in the item/system being checked/inspected. When in doubt, notify your supervisor.

NOTE

When operating with Class I or II leaks, continue to check fluid levels as required in your PMCS.

NOTE

Class III leaks should be reported to your supervisor.

- (a) Class I. Seepage of fluid (as indicated by wetness or discoloration) not great enough to form drops.
- (b) Class II. Leakage of fluid great enough to form drops but not enough to cause drops to drip from item being checked/inspected.
- (c) Class III. Leakage of fluid great enough to form drops that fall from the item being checked/inspected.

Table 2-1. Operator/Crew Preventive Maintenance Checks and Services

NOTE

Within the designated interval, these checks are to be performed in the order listed.

Item No.	B-Before				D-During	A-After	W-Weekly
	Interval				Item To Be Inspected	Procedures: Check for and have repaired filled, or adjusted as needed.	Equipment Is Not Ready/ Available If:
	B	D	A	W			
1	•				WATER PUMP	<p>NOTE</p> <p>Perform lubrication prior to or in conjunction with your PMCS. Refer to LO 10-3510-209-12.</p>  <p>Electric motor (1): Inspect for obstruction to ventilation and for loose mounting.</p>	Motor is loose.

Table 2-1. Operator/Crew Preventive Maintenance Checks and Services(Continued)

Item No.	Interval				Item To Be Inspected	Procedures: Check for and have repaired filled, or adjusted as needed.	Equipment Is Not Ready/ Available If:
	B	D	A	W			
2	●				GENERATOR	 <p>a. Remove large sound deadening panel (1.1) and perform generator PMCS. Refer to TM 5-6115-585-12.</p> <p>b. Remove protective cover on top of batteries and perform PMCS. Refer to TM 5-6115-585-12.</p>	

Table 2-1. Operator/Crew Preventive Maintenance Checks and Services (Continued)

Item No.	Interval				Item To Be Inspected	Procedures: Check for and have repaired filled, or adjusted as needed.	Equipment Is Not Ready/ Available If:
	B	D	A	W			
3	•				WATER HEATER	 <p>a. Fuel shutoff valve (2): Place valve in the open position and check for catching or binding.</p> <p>Clockwise rotation closes valve.</p> <p>Counterclockwise rotation opens valve.</p> <p>b. Ignition cables (3): Inspect for crushed, broken, and loose cables. Secure loose cables.</p> <p>c. Sight glass assembly (4) and combustion sight glass assembly (5): Inspect for broken or missing glass. Ensure sight glass assembly is secure and clean.</p> <p>d. Bleeder valve hose (6): Inspect hose to see if it is loose or missing.</p>	<p>There is catching or binding during rotation.</p> <p>Cables are crushed or broken.</p> <p>Glass is broken or missing.</p> <p>Hose is missing.</p>

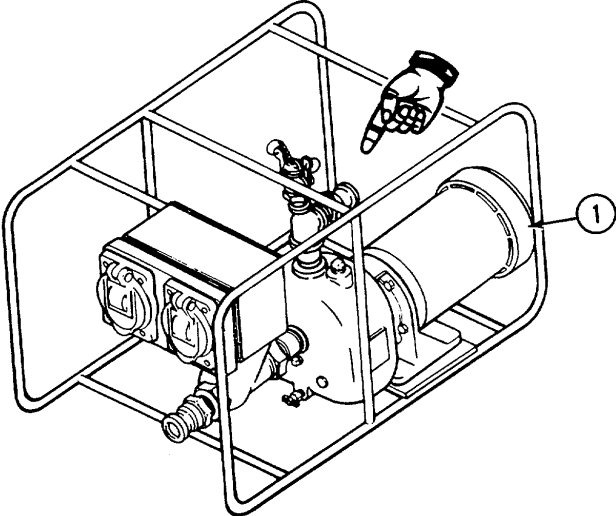
Table 2-1. Operator/Crew Preventive Maintenance Checks and Services (Continued)

Item No.	Interval				Item To Be Inspected	Procedures: Check for and have repaired filled, or adjusted as needed.	Equipment Is Not Ready/ Available If:
	B	D	A	W			
4	•				<p>DRYER ASSEMBLY</p>  <p>a. Fuel shutoff valve (7): Place valve in open position and check for catching or binding. Clockwise rotation closes valve. Counterclockwise rotation opens valve.</p> <p>b. Sight glass assembly (8): Inspect for broken or missing glass. Ensure sight glass assembly is secure and clean.</p>	<p>There is catching or binding during rotation.</p> <p>Glass is broken or missing.</p>	

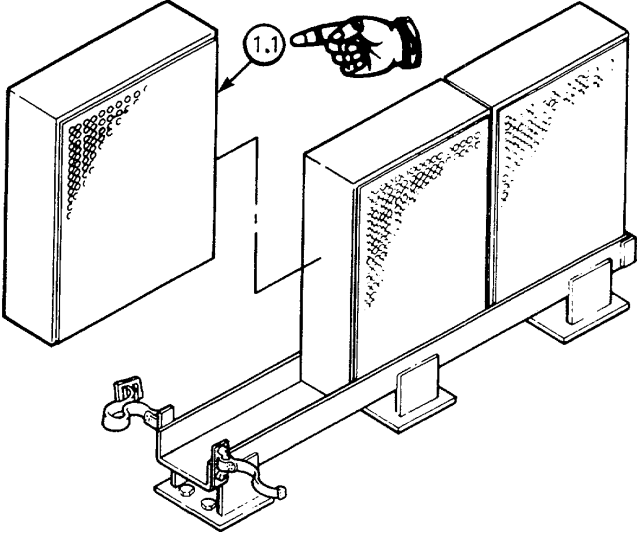
Table 2-1. Operator/Crew Preventive Maintenance Checks and Services (Continued)

Item No.	Interval				Item To Be Inspected	Procedures: Check for and have repaired filled, or adjusted as needed.	Equipment Is Not Ready/ Available If:
	B	D	A	W			
5	•				WASHER ASSEMBLY	 <p>a. Controller assembly (9): Inspect controller window for broken or missing glass. Clean glass as necessary.</p> <p>b. Washer door assembly (10): Inspect glass and seal for cracks, breaks, and missing glass.</p>	<p>Window is missing or broken.</p> <p>Glass is missing or broken.</p>

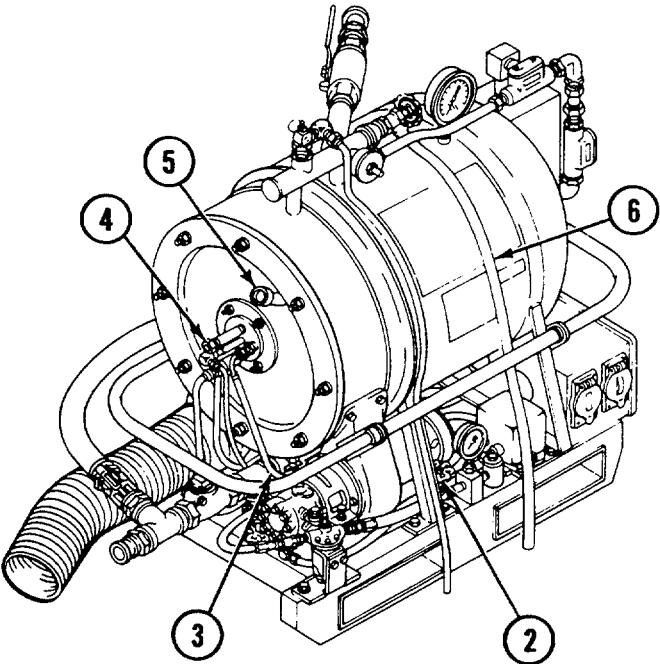
Table 2-1. Operator/Crew Preventive Maintenance Checks and Services (Continued)

Item No.	Interval				Item To Be Inspected	Procedures: Check for and have repaired filled, or adjusted as needed.	Equipment Is Not Ready/ Available If:
	B	D	A	W			
6					FIRE EXTINGUISHER	 <p>a. Inspect fire extinguisher pin (11) for damaged or missing condition.</p> <p>Inspect pressure gage (12) for indication of being fully charged.</p>	Fire extinguisher not fully charged.

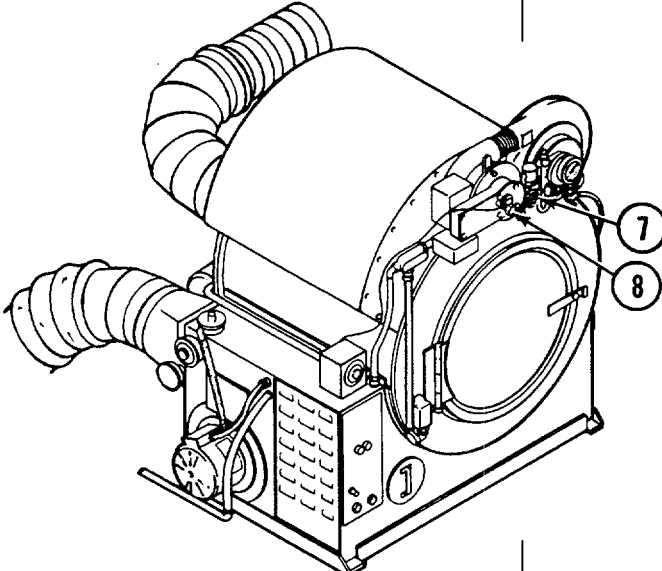
Table 2-1. Operator/Crew Preventive Maintenance Checks and Services (Continued)

Item No.	Interval				Item To Be Inspected	Procedures: Check for and have repaired filled, or adjusted as needed.	Equipment Is Not Ready/ Available If:
	B	D	A	W			
7.		●			WATER HEATER	 <p>a. Gages: After starting water heater, check for the following:</p> <ol style="list-style-type: none"> 1. Temperature gage (13): Normal indication 95 to 160°F (35 to 710C) 2. Fuel pressure gage (14): Normal indication 75 to 80 psi (517 to 552 kPa) 	Gage is broken or indicating above 160°F (71°C) or below 95OF (350C).

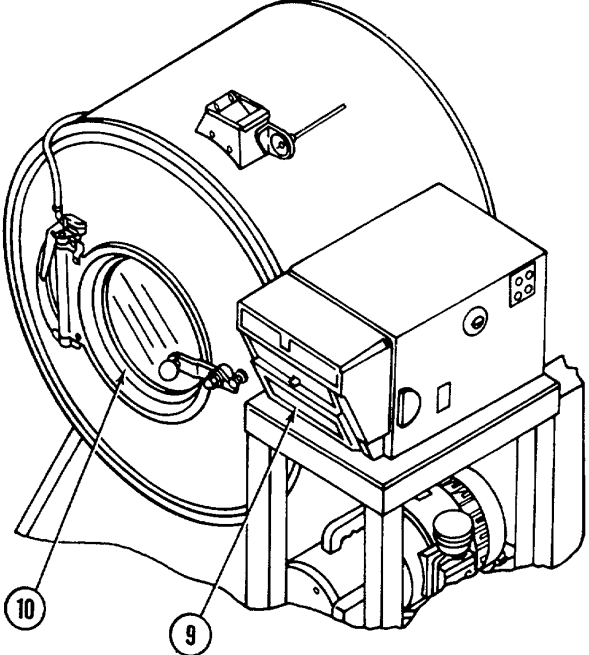
Table 2-1. Operator/Crew Preventive Maintenance Checks and Services (Continued)

Item No.	Interval				Item To Be Inspected	Procedures: Check for and have repaired filled, or adjusted as needed.	Equipment Is Not Ready/ Available If:
	B	D	A	W			
7 (Cont)						<p style="text-align: center;">WARNING</p> <p>Exhaust ducts become very hot during operation. Wear protective gloves when handling hot exhaust ducts. Failure to wear protective gloves could result in severe burns.</p> <p>b. Exhaust duct (15): Visually inspect exhaust duct for leaks.</p> <p>c. Fuel pump, filter, and lines: Inspect for fuel leaks and for kinked or crushed fuel lines.</p> <p>d. Water hoses and lines: Inspect for water leaks and for kinked or crushed hoses or lines.</p>	<p>Exhaust leaks.</p> <p>Lines are leaking, kinked, or crushed.</p>

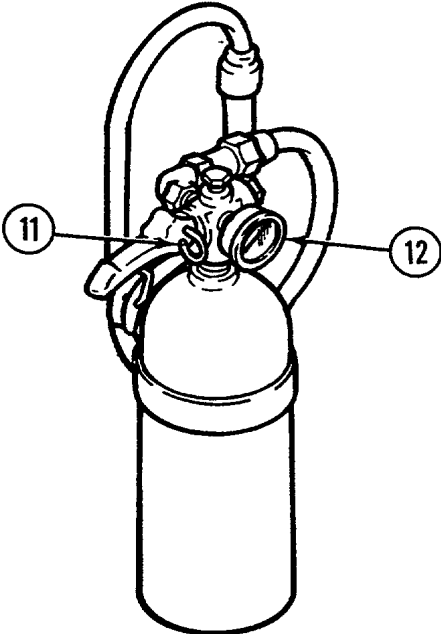
Table 2-1. Operator/Crew Preventive Maintenance Checks and Services (Continued)

Item No.	Interval				Item To Be Inspected	Procedures: Check for and have repaired filled, or adjusted as needed.	Equipment Is Not Ready/ Available If:
	B	D	A	W			
8		●			DRYER ASSEMBLY	 <p>WARNING</p> <p>Exhaust ducts become very hot during operation. Wear protective gloves when handling hot exhaust ducts. Failure to wear protective gloves could result in severe burns.</p> <p>a. Exhaust duct (16): Visually inspect exhaust duct for leaks.</p> <p>b. Fuel pump, filter, and lines: Inspect for fuel leaks and for kinked or crushed fuel lines.</p>	<p>Exhaust leaks.</p> <p>Fuel is leaking or if lines are kinked or crushed.</p>

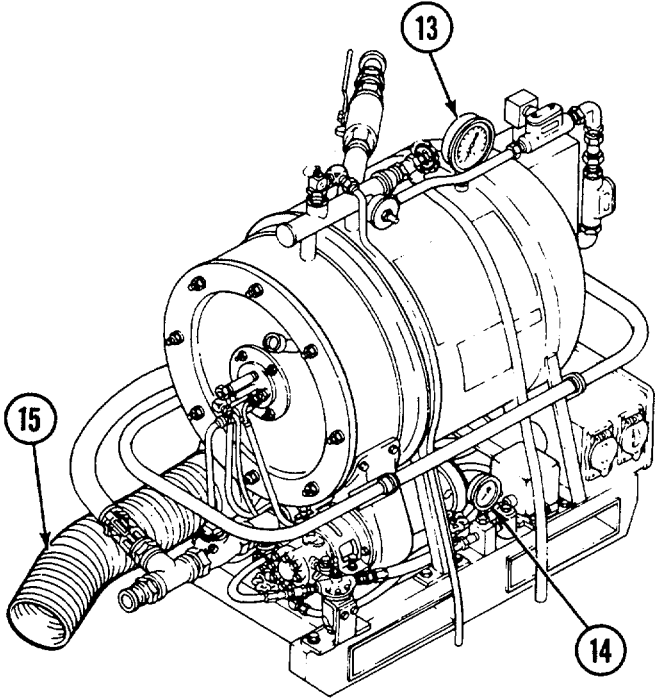
Table 2-1. Operator/Crew Preventive Maintenance Checks and Services (Continued)

Item No.	Interval				Item To Be Inspected	Procedures: Check for and have repaired filled, or adjusted as needed.	Equipment Is Not Ready/ Available If:
	B	D	A	W			
9.			●		WATER PUMP	 <p>Petcock valve (17): Place valve in the open position to drain excess water from the water pump.</p> <p>Clockwise rotation closes valve. Counterclockwise rotation opens valve.</p>	

Table 2-1. Operator/Crew Preventive Maintenance Checks and Services (Continued)

Item No.	Interval				Item To Be Inspected	Procedures: Check for and have repaired filled, or adjusted as needed.	Equipment Is Not Ready/ Available If:
	B	D	A	W			
10			●		GENERATOR	 <p>Remove large sound deadening panel (17.1) and perform PMCS on the generator. Refer to TM 5-6115-585-12.</p>	

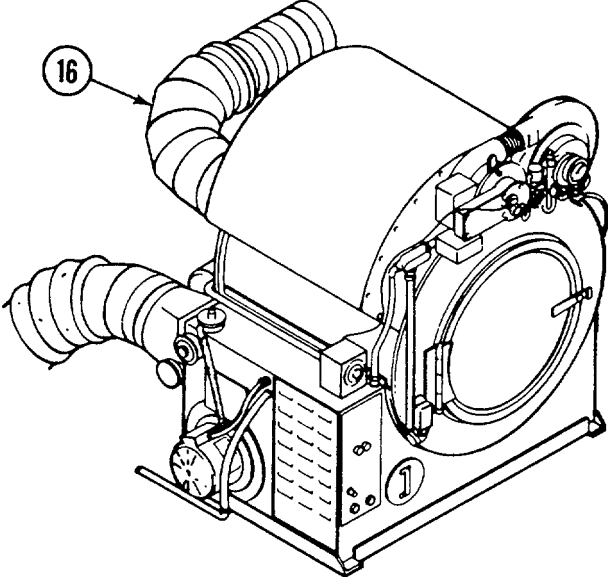
Table 2-1. Operator/Crew Preventive Maintenance Checks and Services (Continued)

Item No.	Interval				Item To Be Inspected	Procedures: Check for and have repaired filled, or adjusted as needed.	Equipment Is Not Ready/ Available If:
	B	D	A	W			
11			●		WATER HEATER	 <p>a. Petcock valve (18): Place valve in open position to drain excess fuel from combustion chamber.</p> <p>Clockwise rotation closes valve.</p> <p>Counterclockwise rotation opens valve.</p> <p>b. Fuel filter (20): Refer to paragraph 3-7 and perform PMCS on water heater fuel filter.</p>	

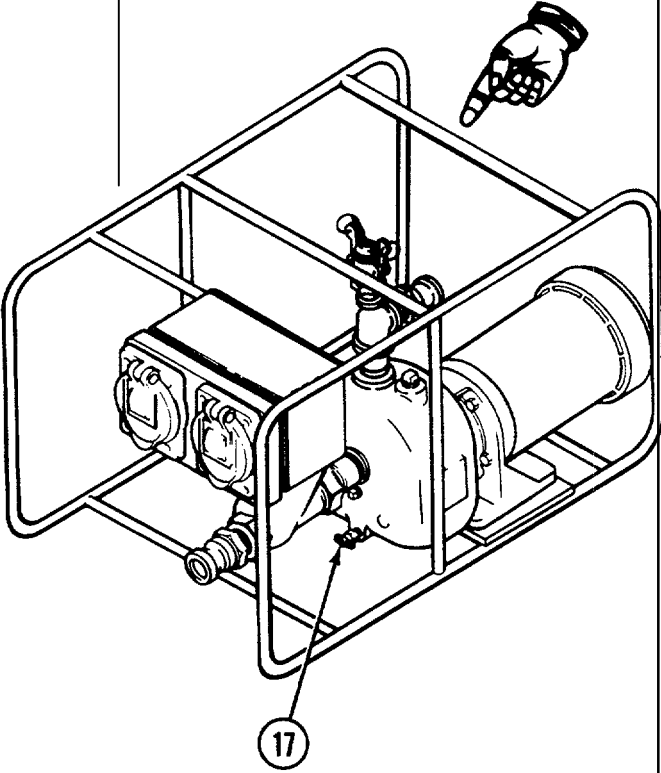
Table 2-1. Operator/Crew Preventive Maintenance Checks and Services (Continued)

Item No.	Interval				Item To Be Inspected	Procedures: Check for and have repaired filled, or adjusted as needed.	Equipment Is Not Ready/ Available If:
	B	D	A	W			
12				•	DRYER HEATER	 <p>Fuel filter (21): Refer to paragraph 3-7 and perform PMCS on dryer fuel filter.</p>	

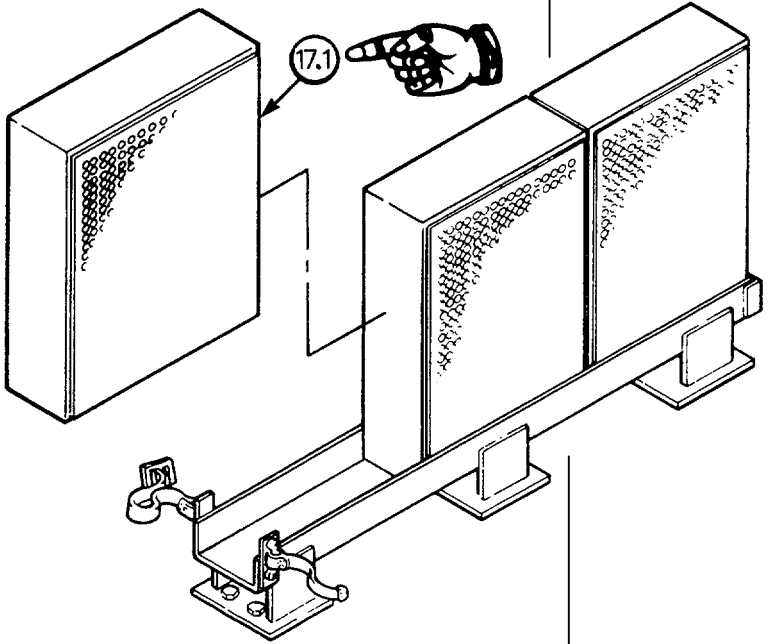
Section III. OPERATION UNDER USUAL CONDITIONS

Para	Title	Page
2-6	Scope.....	2-30
2-7	Site Selection, Setup, and Assembly.....	2-30
2-8	Preparation for Use	2-47
2-9	Operating Procedures	2-62
2-10	Preparation for Movement	2-69
2-11	Operating Instructions on Decals and Instruction Plates.....	2-74

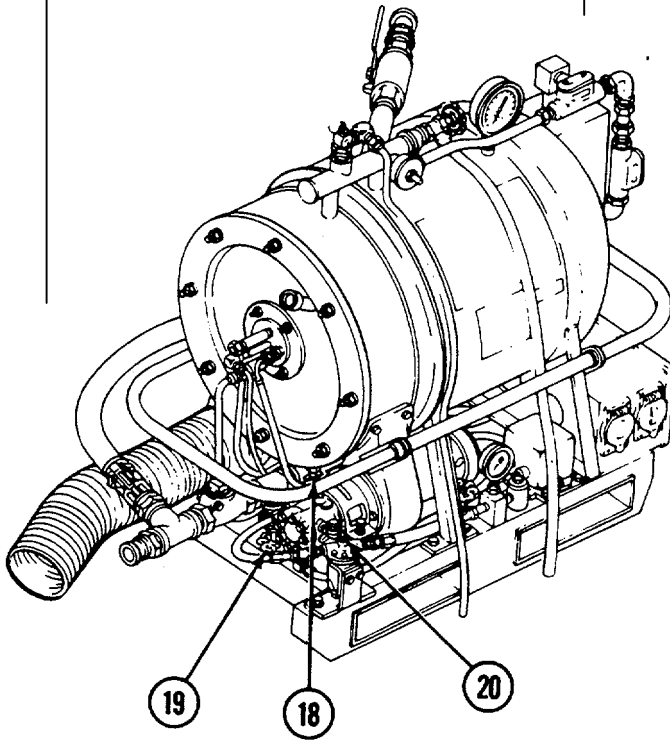
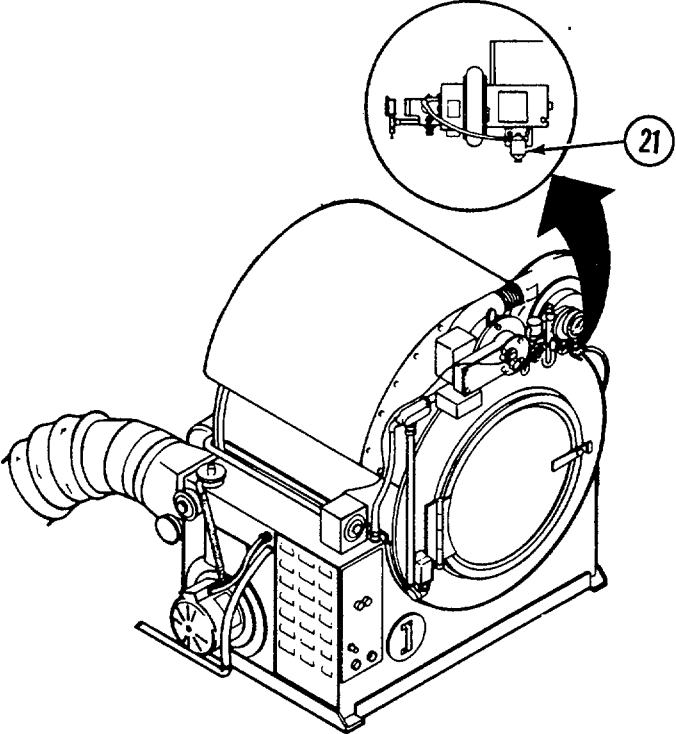
2-6. SCOPE. This section contains procedures for operation of the laundry unit.

2-7. SITE SELECTION, SETUP, AND ASSEMBLY. Components are mounted or stored on the trailer for shipment and storage. During use, some components are removed from the trailer. The setup instructions that follow include steps for unpacking and positioning components. Components should be unpacked only when the facility is planned for use or when maintenance is needed. FIGURE 2-9 shows the laundry unit as it would be for shipping or storage, without the cover.

- a. Select a site for the laundry unit that has adequate water and drainage for operational needs. Select a relatively level area, approximately 75 square feet (6.97 sq m).
 - (1) Position the laundry unit so that the water heater is next to the water source.
 - (2) Set the handbrake lever, lower the trailer supports, and unhitch towing vehicle. If necessary, dig holes or block wheels to ensure the trailer is level. Refer to TM 9-2830-276-14&P.
 - (3) Remove tarp assembly and inspect it for cuts, frays, weather rot, and damage. If tarp assembly is damaged, notify your supervisor.
 - (4) Remove bottom bolts from transportation braces (1) on the left side of trailer assembly. Rotate transportation braces downward into the vertical position.

2-7. SITE SELECTION, SETUP, AND ASSEMBLY. (CONT)

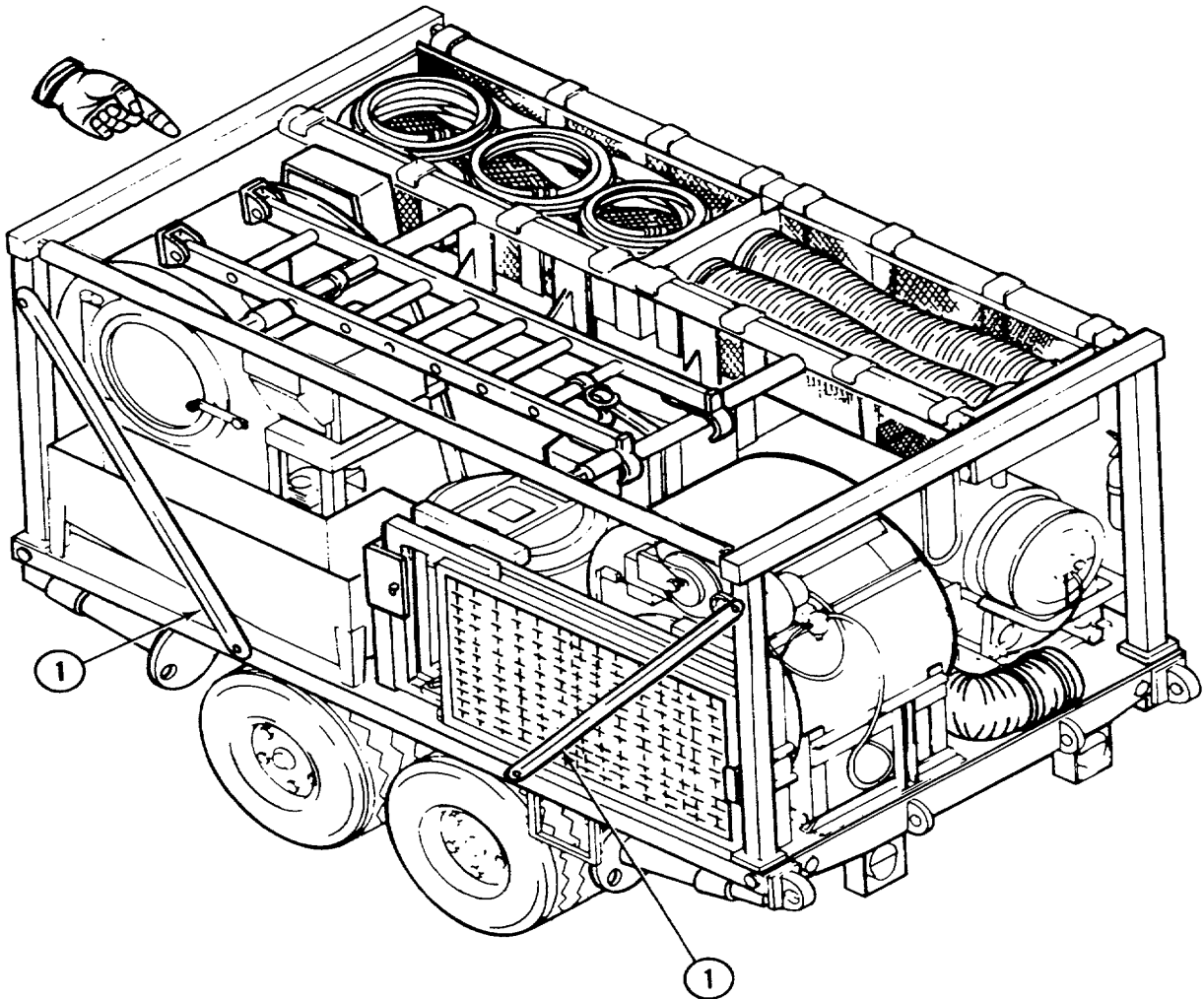

LEFT-REAR VIEW

FIGURE 2-9. Laundry unit transportation mode, without cover. (sheet 1 of 2)

Change 1 2-31

2-7. SITE SELECTION, SETUP, AND ASSEMBLY. (CONT)

NOTE:
TOWING VEHICLE IS
NOT SHOWN FOR
CLARITY.

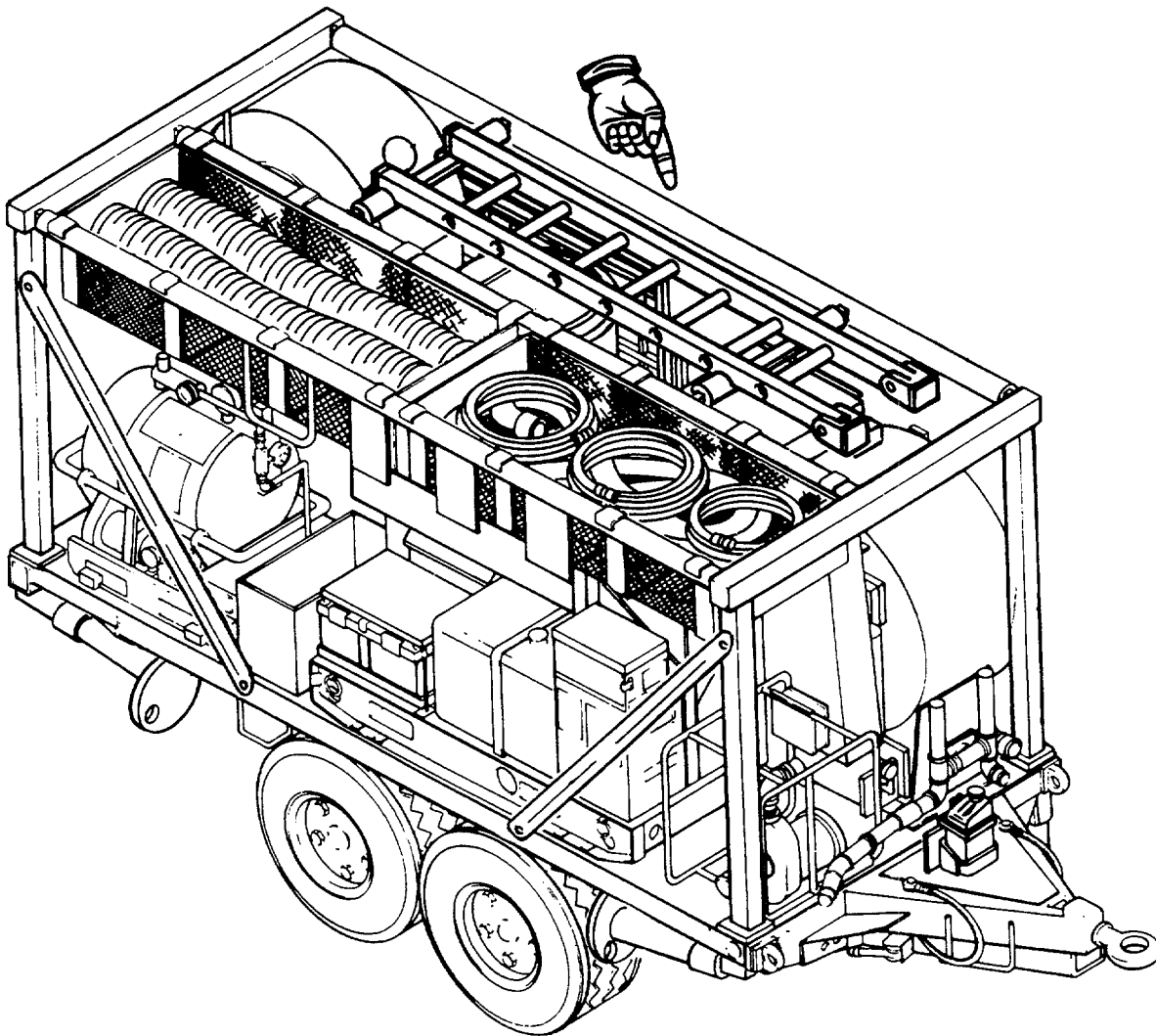

RIGHT-FRONT VIEW

FIGURE 2-9. Laundry unit transportation mode, without cover. (sheet 2 of 2)

2-7. SITE SELECTION, SETUP, AND ASSEMBLY. (CONT)

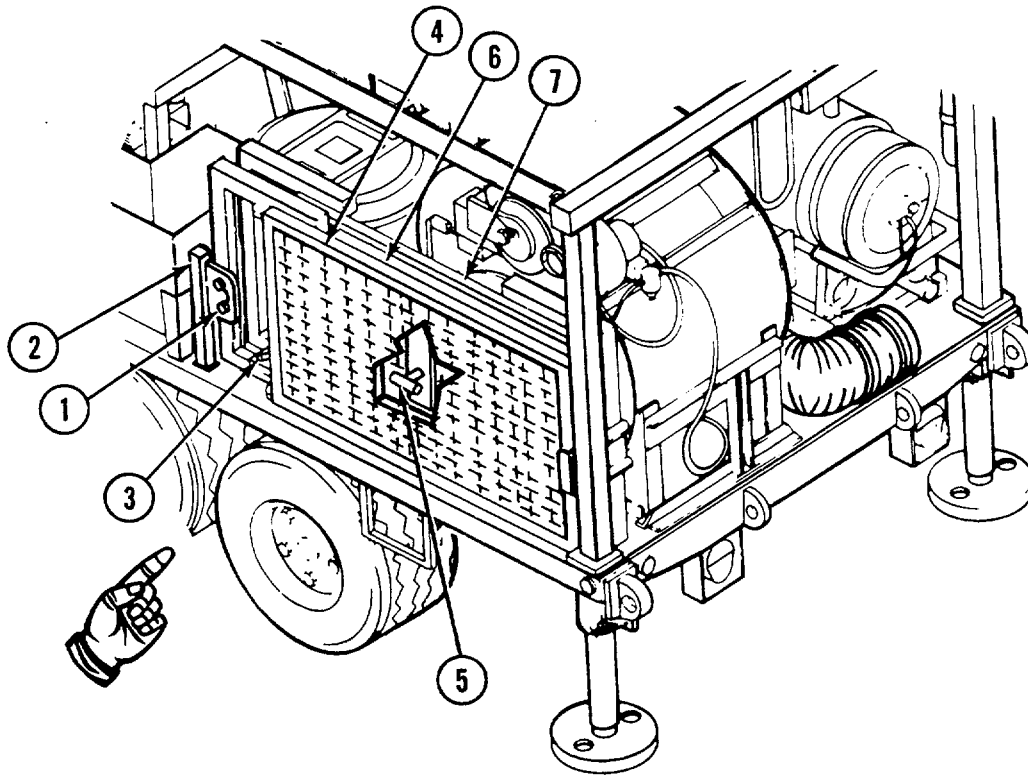

b. Set up platform as follows:

WARNING

This procedure requires at least two people for lifting various components. Failure to observe standard lifting procedures may result in serious injury to personnel.

- (1) Remove ball locking pin (1) from workstand storage support (2) and remove front workstand storage support by lifting up.
- (2) Remove bracket (3) and store in toolbox.
- (3) Slide washer platform (4) toward front of trailer and remove washer platform from trailer.
- (4) Remove clamp (5) from short platform (6) and dryer platform (7).

2-7. SITE SELECTION, SETUP, AND ASSEMBLY. (CONT)

- (5) Remove short platform (6) from trailer and store clamp (5) in tool box.
- (6) Repeat procedures in steps (1) and (3) and remove dryer platform (7).

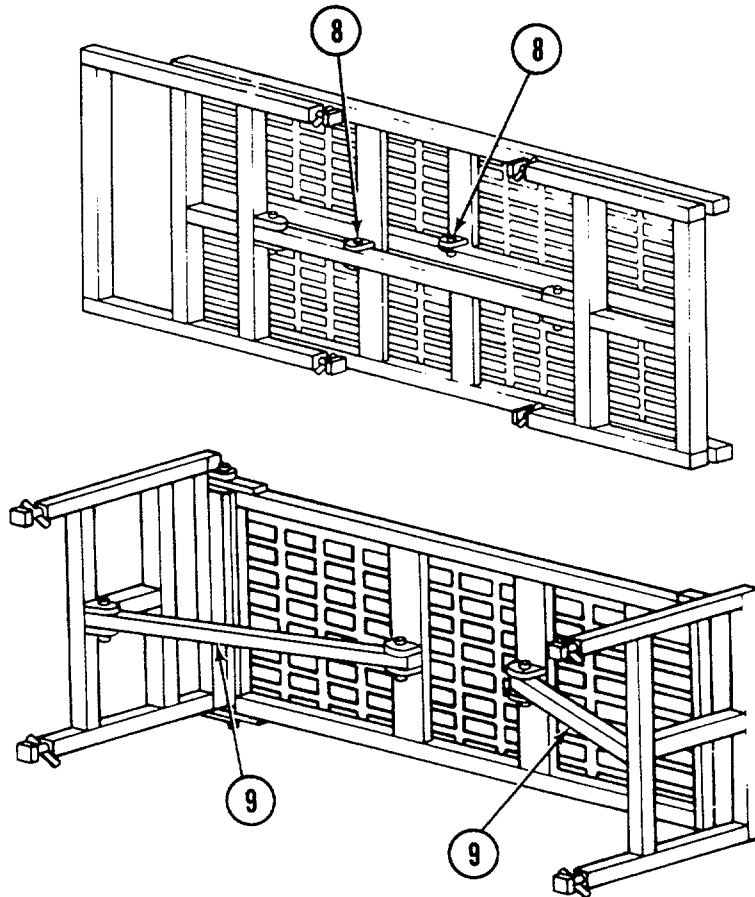

- (7) Remove ball locking pins (8) from platform assemblies. Adjust stabilizer bars (9) and insert ball locking pins in holes provided.

2-7. SITE SELECTION, SETUP, AND ASSEMBLY. (CONT)

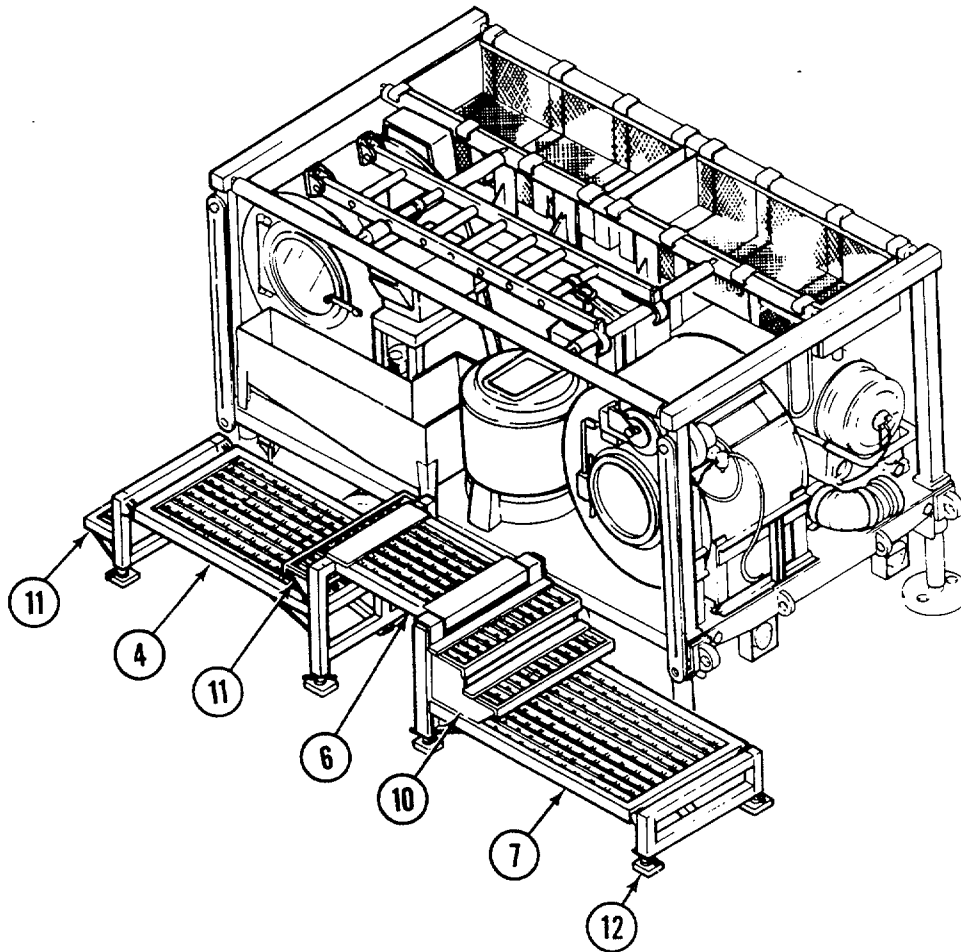

- (8) Place washer platform assembly (4) and dryer platform assembly (7) next to the trailer. Install short platform assembly (6). Remove two steps (11) from pre-extraction bin and install on platform assembly (4).
- (9) Locate and remove step (10) from midsection of trailer and install step on dryer platform (7).
- (10) Adjust leveling plates (12) and brace with footing platforms as needed.

2-7. SITE SELECTION, SETUP, AND ASSEMBLY. (CONT)

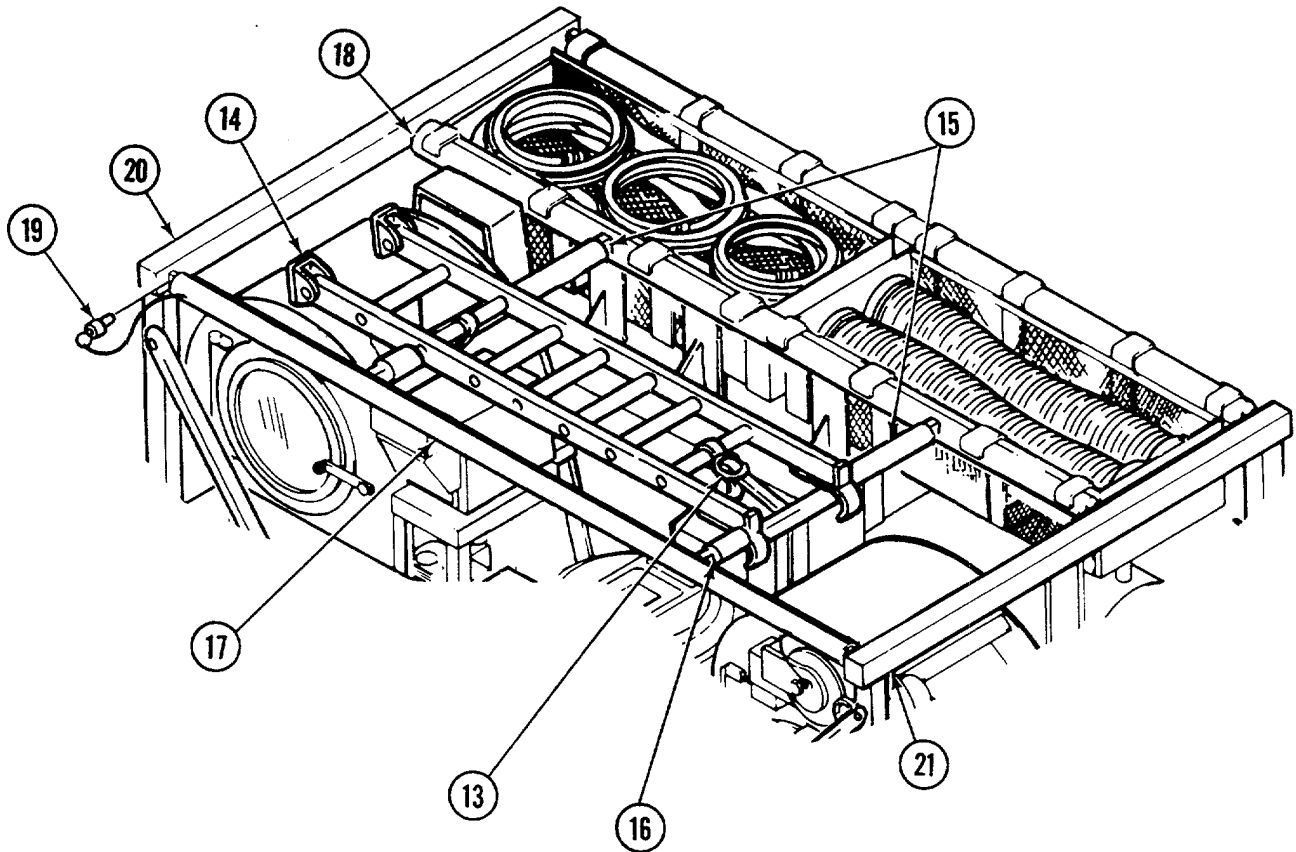

- (11) Unhook two straps (13) and remove ladder (14) from two struts (15).
- (12) Remove four ball locking pins (16) from left beam (17) and center beam, (18) and remove two struts (15).
- (13) Remove two ball locking pins (19) from left beam (17) and remove left beam from frame assemblies (20) and (21). Store left beam underneath trailer.

2-7. SITE SELECTION, SETUP, AND ASSEMBLY. (CONT)

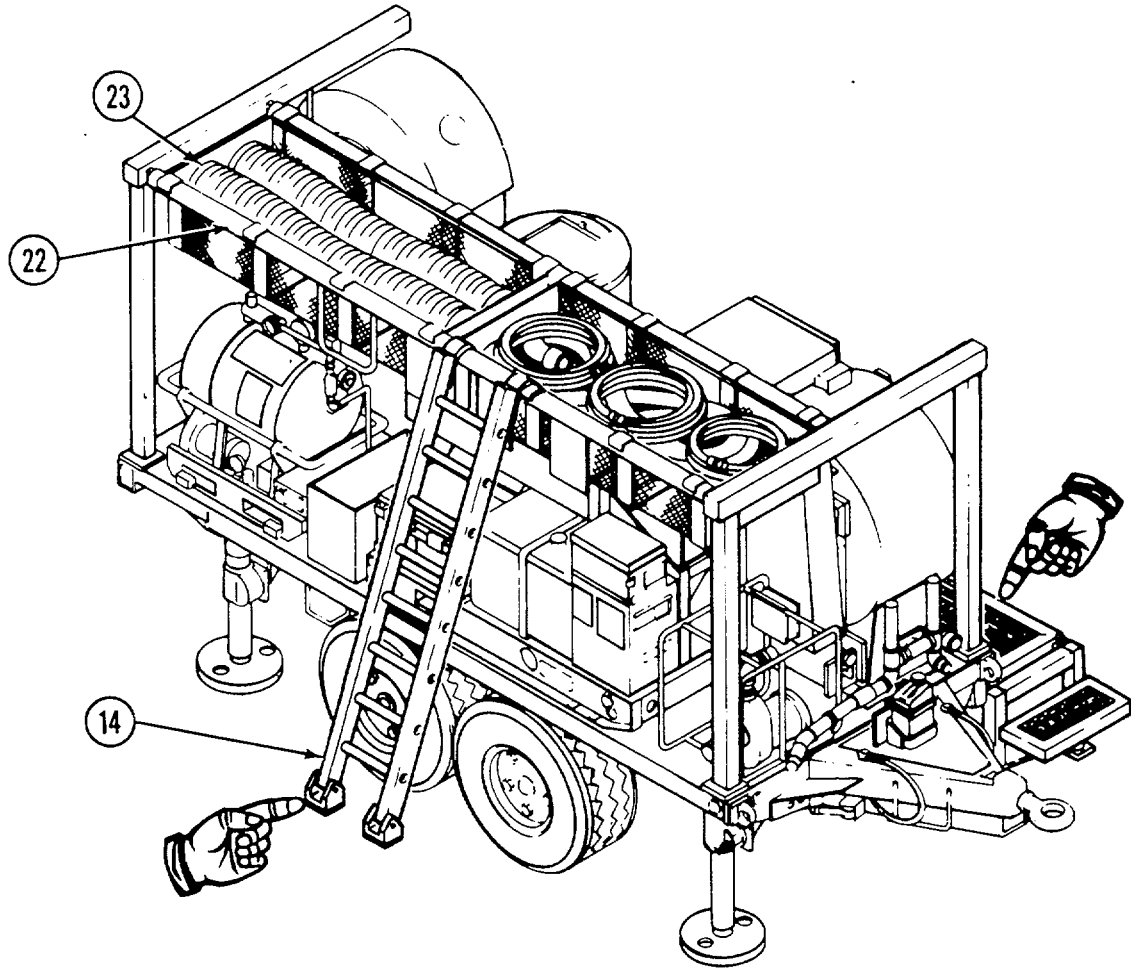

(14) Position ladder (14) on right beam (22) as required.

(15) Remove contents from hose basket assemblies (23).

(16) Store tarp assembly, two struts, and workstand storage supports in hose basket assemblies (23).

c. Set up water pump and hose assembly as follows:

(1) Identify bracket assembly (1) which is located on the left-hand side of the water pump assembly.

2-7. SITE SELECTION, SETUP, AND ASSEMBLY. (CONT)

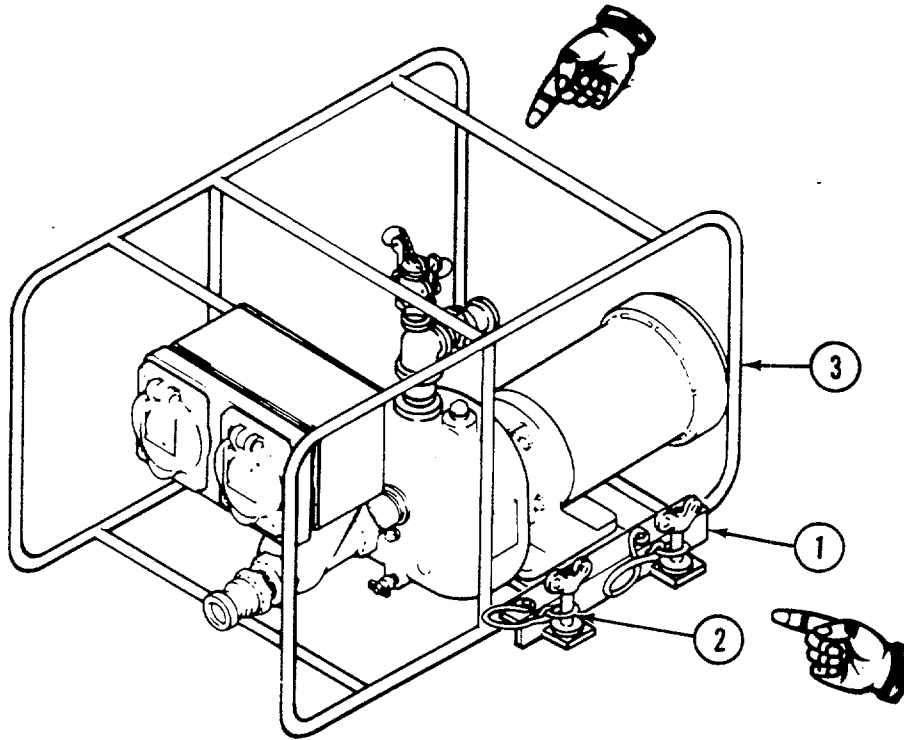

- (2) Remove two wingnuts (2) and remove bracket assembly (1).
- (3) Remove water pump (3) and locate it no more than 10 feet (3 m) from the water source.
- (4) Install bracket (1) and tighten wingnuts (2) removed in step (2).
- (5) Connect suction hose (1, FIG. 2-10) to suction inlet (2).

WARNING

Ensure that water hoses (1 and 4, FIG. 2-10) do not touch or cross other water hoses, exhaust ducts, power cables, or fuel lines. Melting/damage can occur causing leaking fuel and water or electrical hazards. Death by electrocution, fire, or explosion could result.

- (6) Connect suction strainer(3) to the other end of suction hose (1). Position the strainer in the water source above the stream bed. Make a tripod from tree branches or saplings and hang the strainer from the place where the branches are tied together, or position the strainer on a bed of stones or gravel.
- (7) Connect water heater intake hose (4) to water pump discharge outlet (5).
- (8) Connect the other end of water heater intake hose (4) to water heater inlet (6).
- (9) Deleted

2-7. SITE SELECTION, SETUP, AND ASSEMBLY. (CONT)

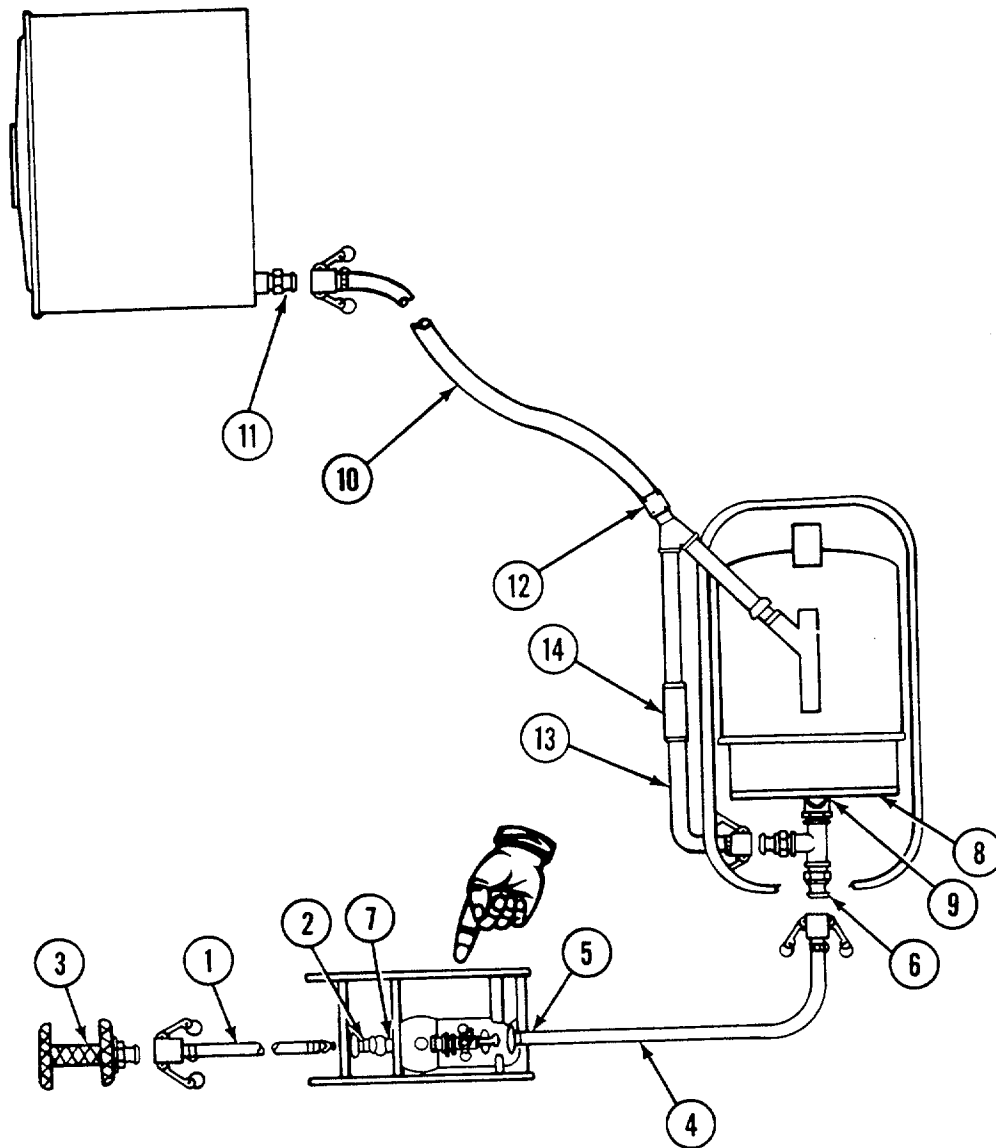

FIGURE 2-10. Water hose connection diagram.

Change 1 2-39

2-7. SITE SELECTION, SETUP, AND ASSEMBLY. (CONT)

- (10) Ensure petcock valve (7) on water pump housing is closed. Clockwise rotation closes valve.
- (11) Ensure petcock valve (8) and drain valve (9) on the water heater are closed. Clockwise rotation closes valve.
- (12) Ensure washer inlet hose (10) is connected to washer inlet (11) and to water heater outlet (12).
- (13) Ensure that hose (13) from water heater inlet (6) is connected to piping assembly (14).
- (14) Ensure that drain hose (1, FIG. 2-11) is connected to extractor drain connection (2) and washer drain connection (3).

WARNING

Ensure that drain hoses (4 and 6, FIG. 2-11) do not touch or cross other water hoses, power cables, exhaust ducts, or fuel lines. Melting/damage can occur causing leaking fuel and water or electrical hazards. Death by electrocution, fire, or explosion could result.

- (15) Connect one 25-foot (7.6 m), 1-1/2-inch-diameter drain hose (4) to pre-extraction bin drain (5) and route the hose to a drain field. Do not touch or cross other water hoses, power cables, exhaust ducts, or fuel lines.
 - (16) Connect one 25-foot (7.6 m), 2-1/2-inch-diameter drain hose (6) to washer drain (7) and route the hose to a drain field. Do not touch or cross other water hoses, power cables, exhaust ducts, or fuel lines.
- d. Set up electric power cables as follows:

WARNING

The laundry unit uses 208 V ac. All circuit breakers on the electrical panel must be off prior to connecting electrical power cables. Failure to observe safety precautions may result in death or serious injury.

- (1) Open electrical panel door (1, FIG. 2-12) and turn off all circuit breakers (2).
- (2) Remove dust cap (3) on main power connection (4).

2-7. SITE SELECTION, SETUP, AND ASSEMBLY. (CONT)

- (3) Connect main power cable (5) to main power connection (4). Connect other end of power cable to power source. Refer to TM 5-6115-585-12 for electrical connections on generator.

WARNING

Ensure that power cable (6, FIG. 2-12) does not touch or cross water hoses, exhaust ducts, or fuel lines. Melting/damage can occur causing leaking fuel and water or electrical hazards. Death by electrocution, fire, or explosion could result.

NOTE

Lock power cables in place by rotating connector clockwise.

- (4) Connect water pump cable (6) between water heater service outlet (7) and water pump service outlet (8). Do not touch or cross water hoses, exhaust ducts, or fuel lines.
- (5) Ensure water pump ON/OFF switch is in the OFF position.
- (6) Ensure water heater load limit switch is in the OFF position.

Change 1 2-40.1/(2-40.2 blank)

2-7. SITE SELECTION, SETUP, AND ASSEMBLY. (CONT)

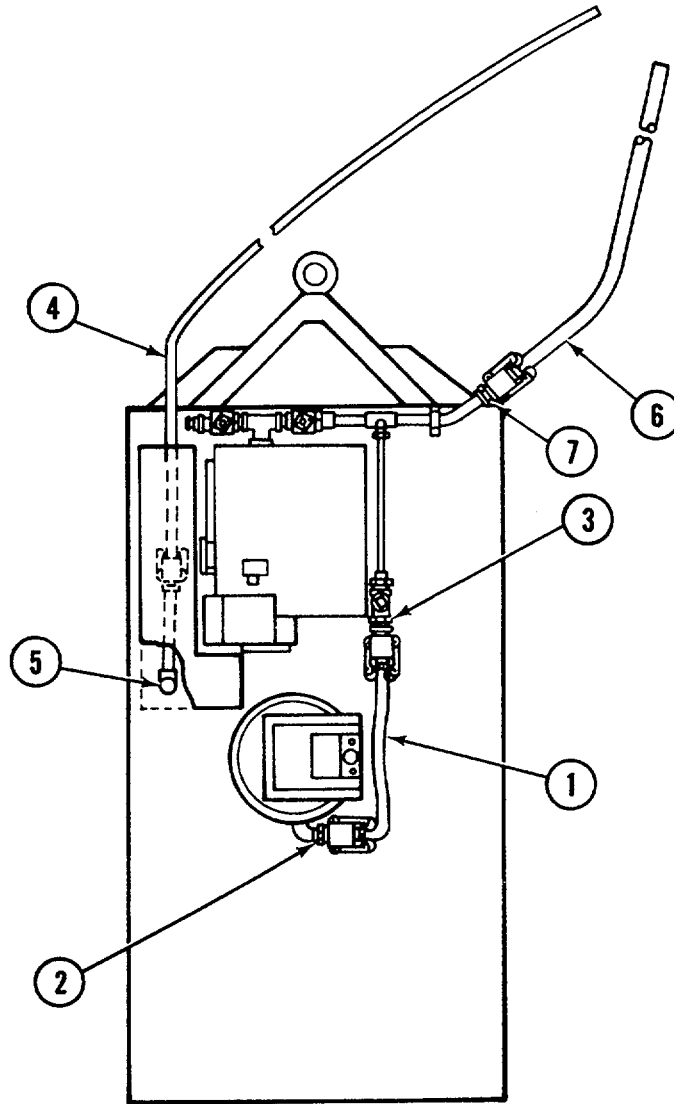

FIGURE 2-11. Drain hose connection diagram.

2-7. SITE SELECTION, SETUP, AND ASSEMBLY. (CONT)

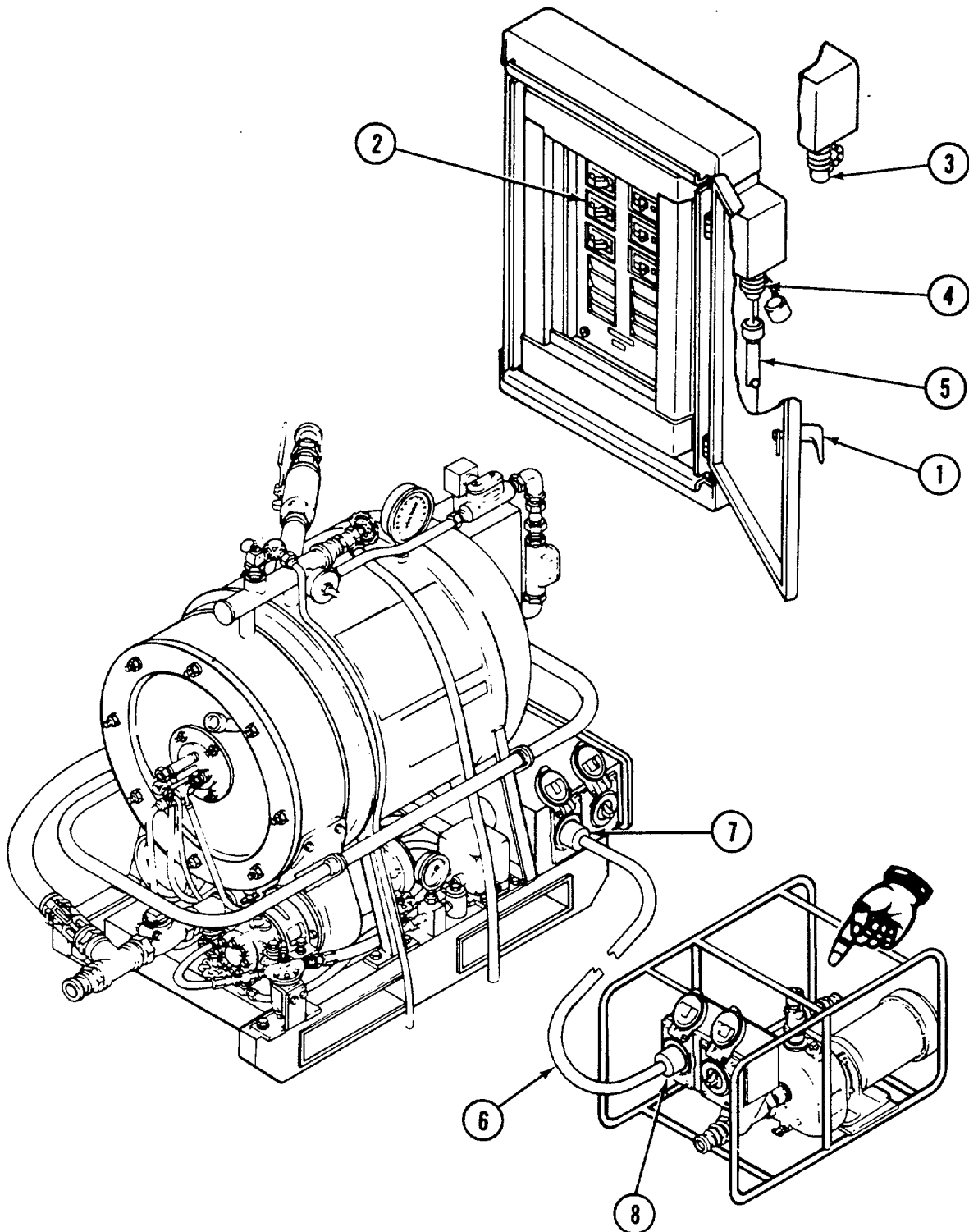

FIGURE 2-12. Electrical panel cable connection.

2-7. SITE SELECTION, SETUP, AND ASSEMBLY. (CONT)

- e. Remove and install dryer bin as follows:
 - (1) Remove four bolts (1, FIG. 2-13) located inside dryer bin (2).
 - (2) Remove dryer bin (2) and place it in front of dryer assembly (3).
 - (3) Install bolts (1) removed in step (1) in the same locations from which they were removed.
- f. Make dryer fuel line connections as follows:

WARNING

Use only specified fuel (item 10, app C). Failure to do so may result in death or serious injury to personnel or damage to equipment.

- (1) Obtain two fuel lines (1, FIG. 2-14).

WARNING

Ensure that fuel lines (1, FIG. 2-14) do not touch or cross water hoses, power cables, or exhaust ducts. Melting/damage can occur causing leaking fuel and water or electrical hazards. Death by electrocution, fire, or explosion could result.

- (2) Connect one fuel line (1) to fuel filter inlet (2) and one fuel line to fuel pump outlet (3).
- (3) Connect the other ends of fuel lines (1) to drum fill adapter (4). The line from the fuel filter connects to fitting labeled SUPPLY on drum fill adapter. The line from the bottom of fuel pump connects to fitting labeled RETURN on the drum fill adapter.

NOTE

The drum fill adapter can be used with 55-gallon (208 liter) drums (5), 5-gallon (19 liter) cans (6), or other fuel sources.

- (4) If a 55-gallon (208 liter) drum (5) is being used as the fuel source, remove drum fill adapter extension (7) from the bottom of the return port and install it in the drum fill adapter pipe. When using 5-gallon (19 liter) cans (6), the extension remains attached to the return port.

2-7. SITE SELECTION, SETUP, AND ASSEMBLY. (CONT)

- g. Make water heater fuel line connections as follows:

WARNING

Use only specified fuel (item 10, app C). Failure to do so may result in death or serious injury to personnel or damage to equipment.

- (1) Obtain two fuel lines (1, FIG. 2-15).

WARNING

Ensure that fuel lines (1, FIG. 2-15) do not touch or cross water hoses, power cables, or exhaust ducts. Melting/damage can occur causing leaking fuel and water or electrical hazards. Death by electrocution, fire, or explosion could result.

- (2) Connect one fuel line (1) to fuel filter inlet (2) and one fuel line to fuel pump outlet (3).

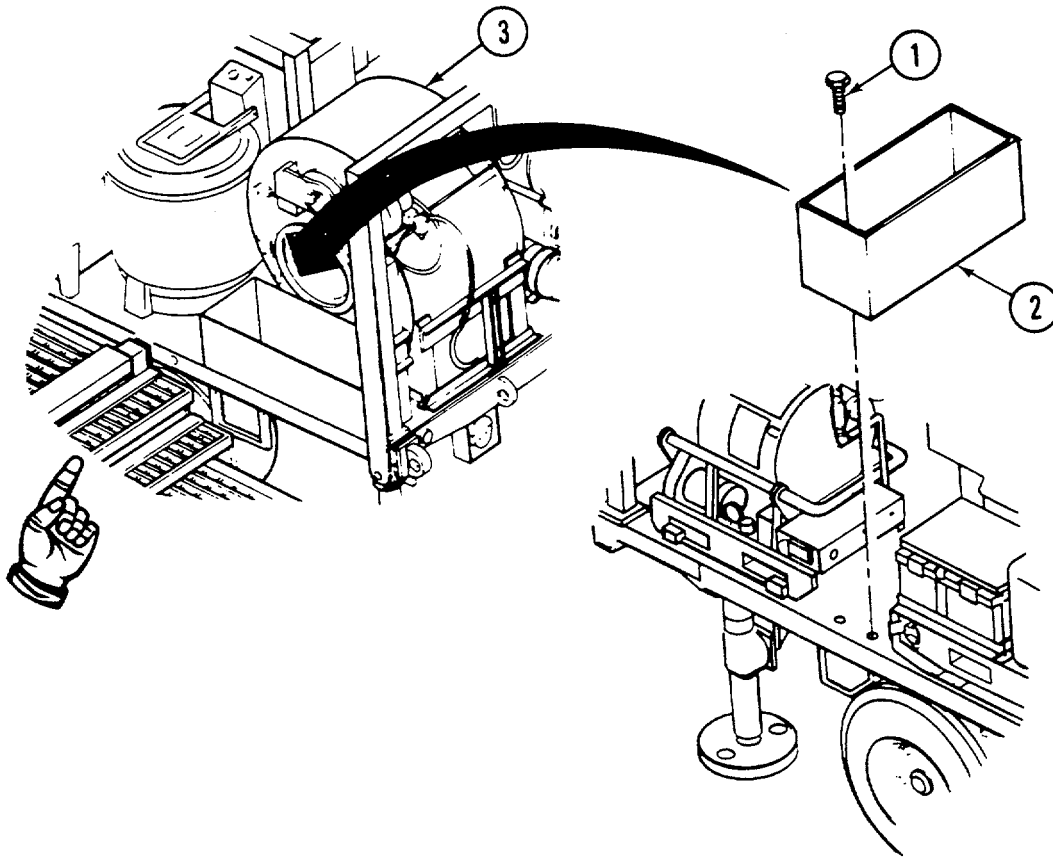

FIGURE 2-13. Dryer bin removal and installation.

2-7. SITE SELECTION, SETUP, AND ASSEMBLY. (CONT)

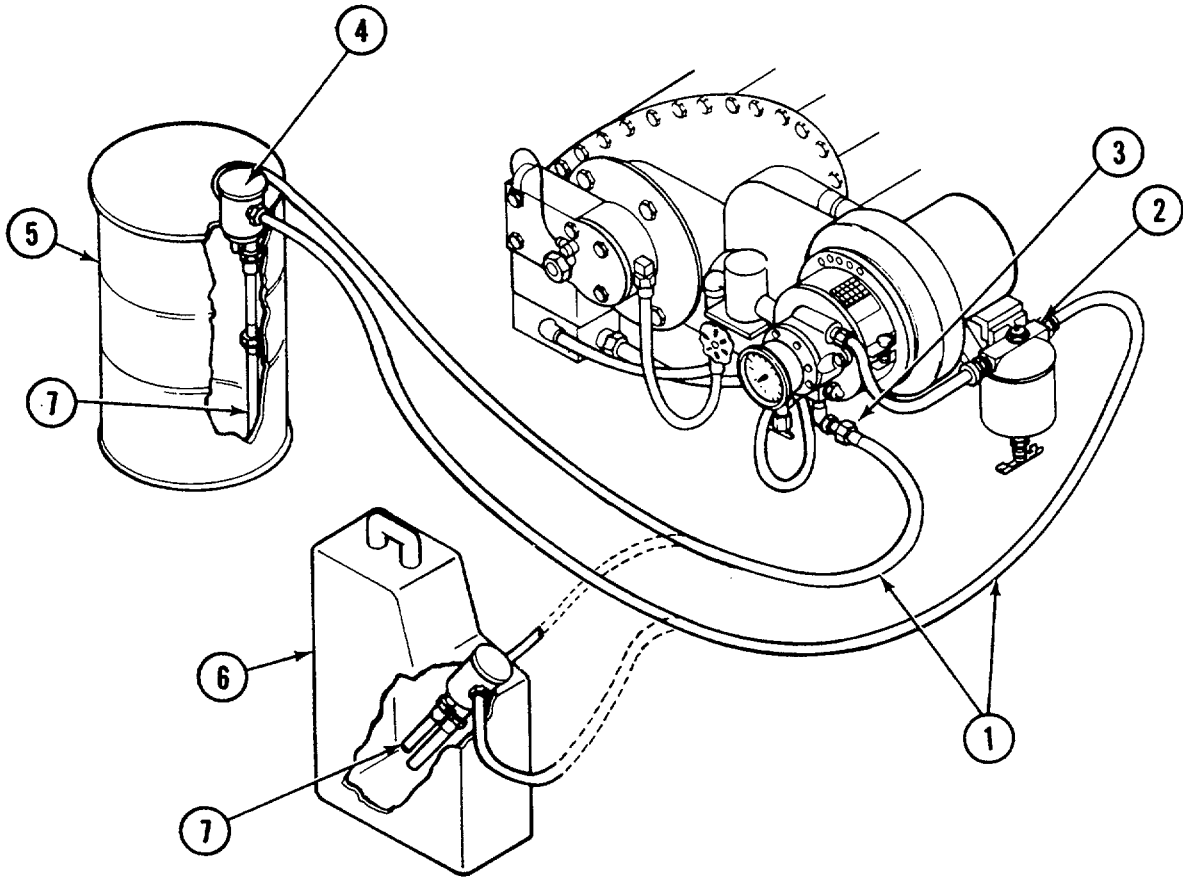

FIGURE 2-14. Dryer fuel line connections.

2-7. SITE SELECTION, SETUP, AND ASSEMBLY. (CONT)

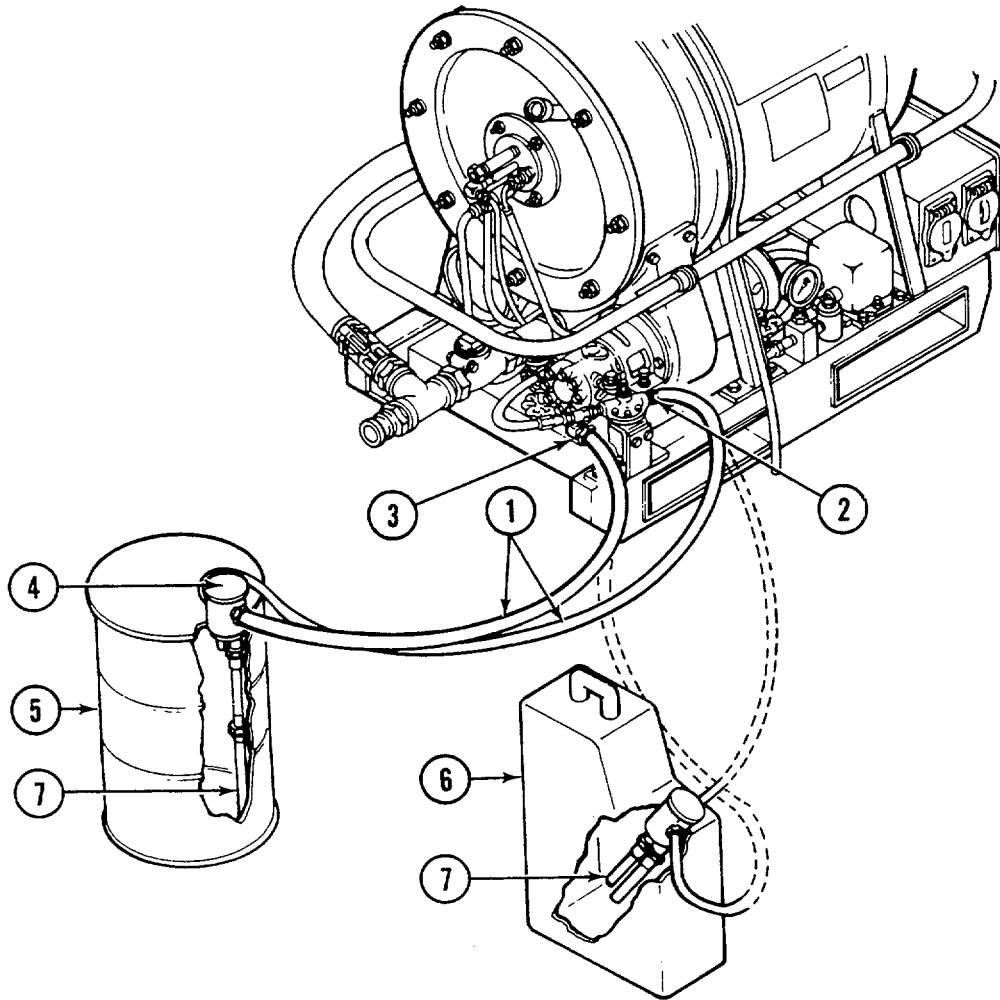

FIGURE 2-15. Water heater fuel line connections.

2-7. SITE SELECTION, SETUP, AND ASSEMBLY. (CONT)

- (3) Connect the other ends of fuel lines (1) to drum fill adapter (4). The line from the fuel filter connects to fitting labeled SUPPLY on the drum fill adapter. The line from the bottom of fuel pump connects to fitting labeled RETURN on the drum fill adapter.

NOTE

The drum fill adapter can be used with 55-gallon (208 liter) drums (5), 5-gallon (19 liter) cans (6), or other fuel sources.

- (4) If a 55-gallon (208 liter) drum (5) is being used as the fuel source, remove drum fill adapter extension (7) from the bottom of the return port and install it in the drum fill adapter pipe. When using 5-gallon (19 liter) cans (6), the extension remains attached to the return port.
- h. Make exhaust hose connections as follows:

WARNING

Carbon monoxide is dangerous. Ensure that exhausts are properly vented to an open-air area. Death or serious injury to personnel can result from heavy exposure to exhaust gas.

- (1) Unhook three straps (1, FIG. 2-16) and remove combustion exhaust ducts
- (2) from trailer assembly (3).

WARNING

Ensure that exhaust ducts (1, 3, 5, and 7, FIG. 2-17) do not touch or cross other exhaust ducts, power cables, fuel lines, or water hoses. Melting/damage can occur causing leaking fuel and water or electrical hazards. Death by electrocution, fire, or explosion could result.

- (2) Connect 5-inch (127 mm) combustion exhaust duct (1, FIG. 2-17) to dryer exhaust port (2). Extend duct away from trailer assembly. Do not touch or cross other exhaust ducts, power cables, water hoses, or fuel lines.

NOTE

The dryer lint duct is stored inside the dryer assembly during transportation.

- (3) Obtain 12-inch (305 mm) lint duct (3) and install on dryer lint duct port
- (4) Extend duct full length along right side of trailer. Do not touch or cross other exhaust ducts, power cables, water hoses, or fuel lines.

2-7. SITE SELECTION, SETUP, AND ASSEMBLY. (CONT)

- (4) Connect two 7-inch (178 mm) combustion exhaust ducts (5) together and connect to water heater exhaust port (6). Extend duct full length away from rear of trailer. Do not touch or cross other exhaust ducts, power cables, water hoses, or fuel lines.
- (5) Connect two 2-inch combustion exhaust ducts (7) to generator exhaust ports (8). Extend ducts away from trailer assembly. Do not touch or cross other exhaust ducts, power cables, water hoses, or fuel lines.

2-8. PREPARATION FOR USE.

- a. Generator. Ensure that the ON/OFF switch on the water pump and water heater are in the OFF position and that all circuit breakers in the power distribution box are turned off.

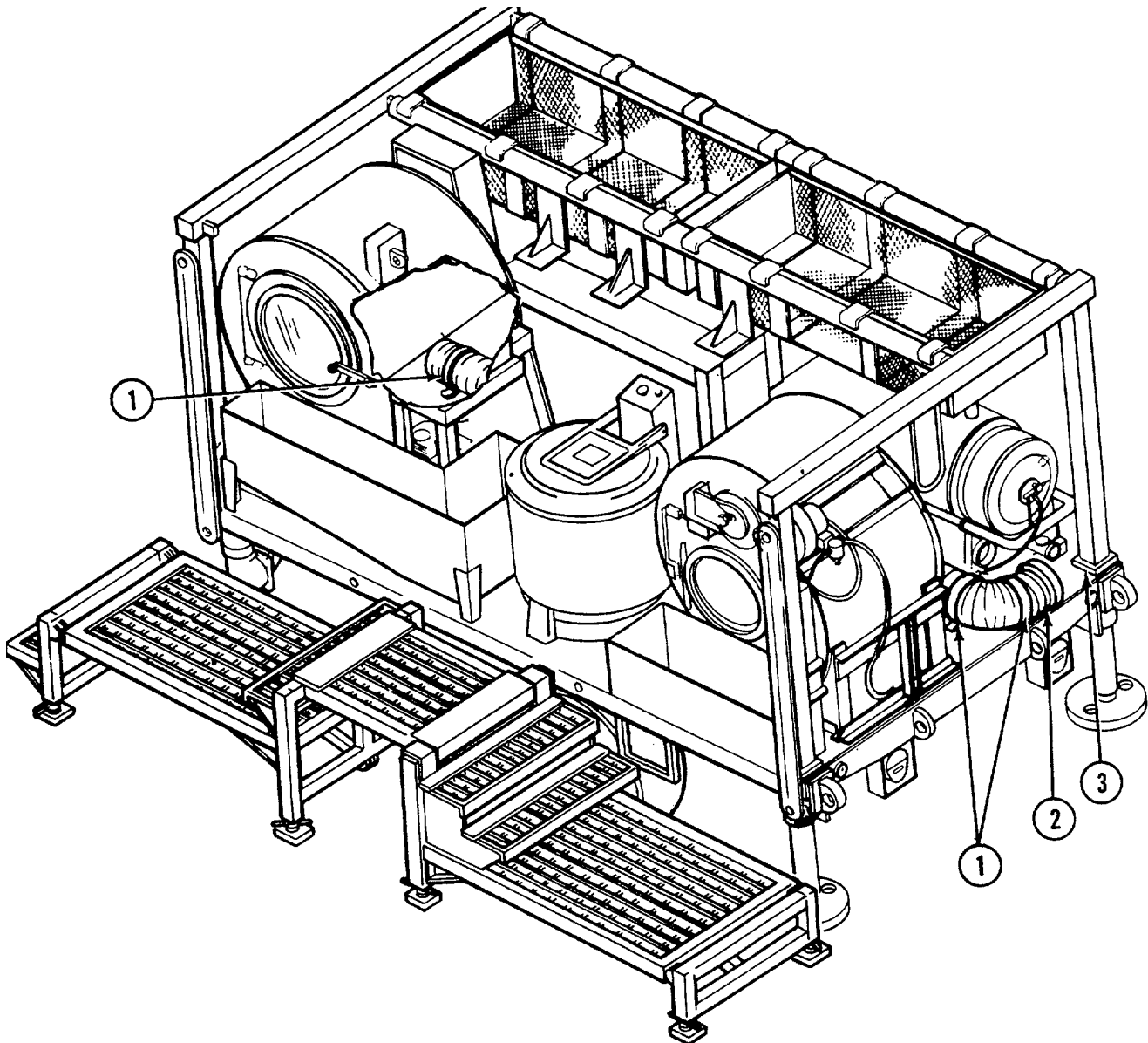

FIGURE 2-16. Exhaust duct removal from trailer.

2-8. PREPARATION FOR USE. (CONT)

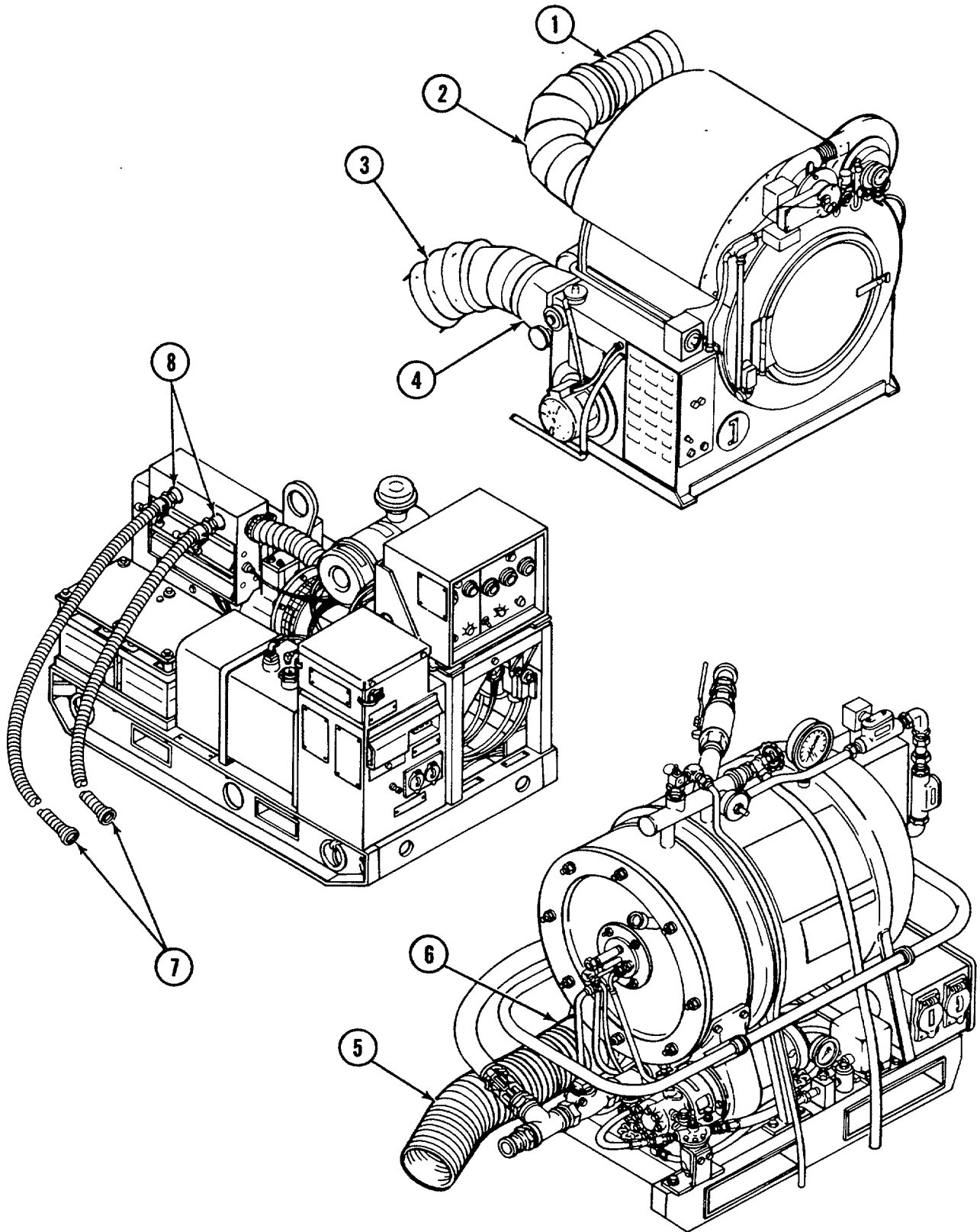

FIGURE 2-17. Exhaust hose connections.

2-8. PREPARATION FOR USE. (CONT)

b. Generator.

WARNING

Do not operate the unit until the ground terminal stud of the engine-generator set has been connected to a suitable ground. Electrical faults in the engine-generator set, load lines, or load equipment can cause death by electrocution from contact with an ungrounded system.

WARNING

Do not touch exhaust ducts while running or immediately after shutdown, as severe burns may result.

NOTE

The air compressor will operate when power is applied to the laundry facility and the circuit breaker is on.

- (1) Refer to TM 5-6115-585-12 for starting procedures for the generator and start the generator.
- (2) Turn on all circuit breakers at power distribution panel.

c. Air Compressor.

- (1) Wait 2 minutes for pressure to build up inside air tank assembly and check air tank gage (1, FIG. 2-18) for an indication of 60 to 80 psi (414 to 552 kPa).
- (2) Open drain valve (2) to bleed condensation from air tank (3).
- (3) Close drain valve.
- (4) Turn off generator. (Refer to TM 5-6115-585-12.)
- (5) Listen for air leaks. If air leaks are found, report the problem to your supervisor. If leaks are not found, restart generator.

2-8. PREPARATION FOR USE. (CONT)

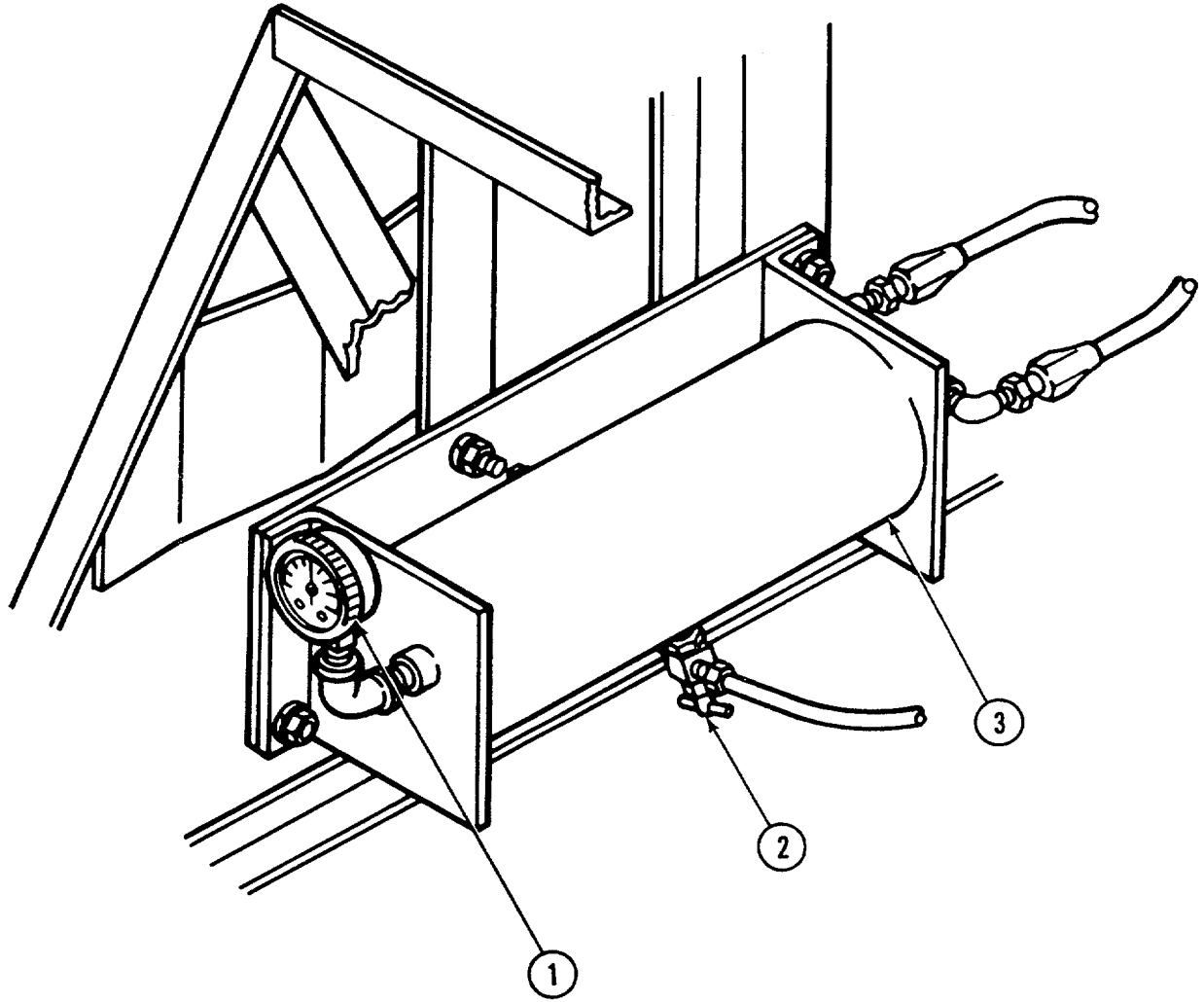
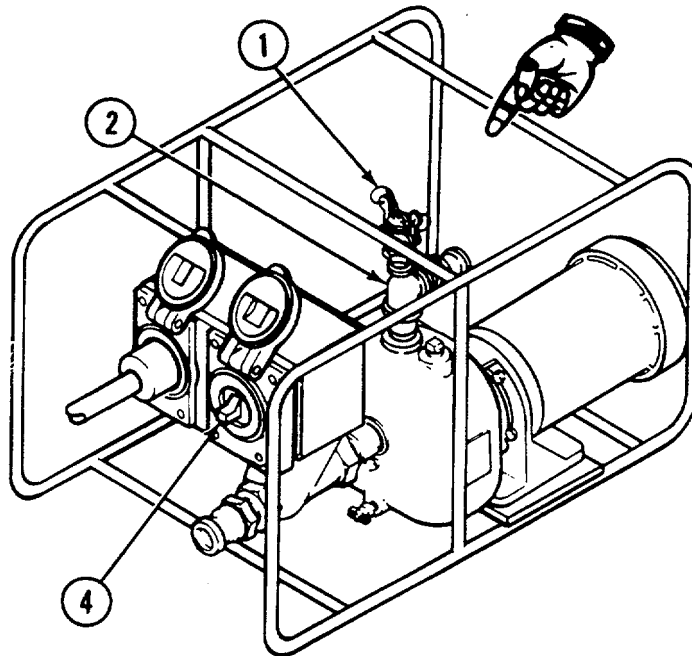

FIGURE 2-18. Air tank controls.

2-8. PREPARATION FOR USE. (CONT)

d. Water Pump.

- (1) Remove priming plug (1) located at the top of pump housing (2).
- (2) Deleted
- (3) Prime pump with clean water.
- (4) Replace priming plug (1).
- (5) Set ON/OFF switch (4) on the water pump to ON then OFF. Inspect motor for correct rotation. Refer to table 3-2, malfunction 1, step 2, for rotation check. If motor is rotating in correct direction, place switch in the ON position.

e. Water Heater.

- (1) Ensure fuel shutoff valve (4, FIG. 2-19) is closed. Clockwise rotation closes valve.
- (2) Set switch (1) on the water heater to the ON position, then to the OFF position, and check for proper motor rotation. If motor does not rotate in direction of arrows, refer to similar water pump troubleshooting table 3-2, malfunction 1, step 2. If motor is rotating in correct direction, place switch in the ON position.
- (3) Open water outlet valve (13).
- (4) Open bleeder valve (2) until a steady stream of water flows from vent hose (3). Close the valve.

2-8. PREPARATION FOR USE. (CONT)

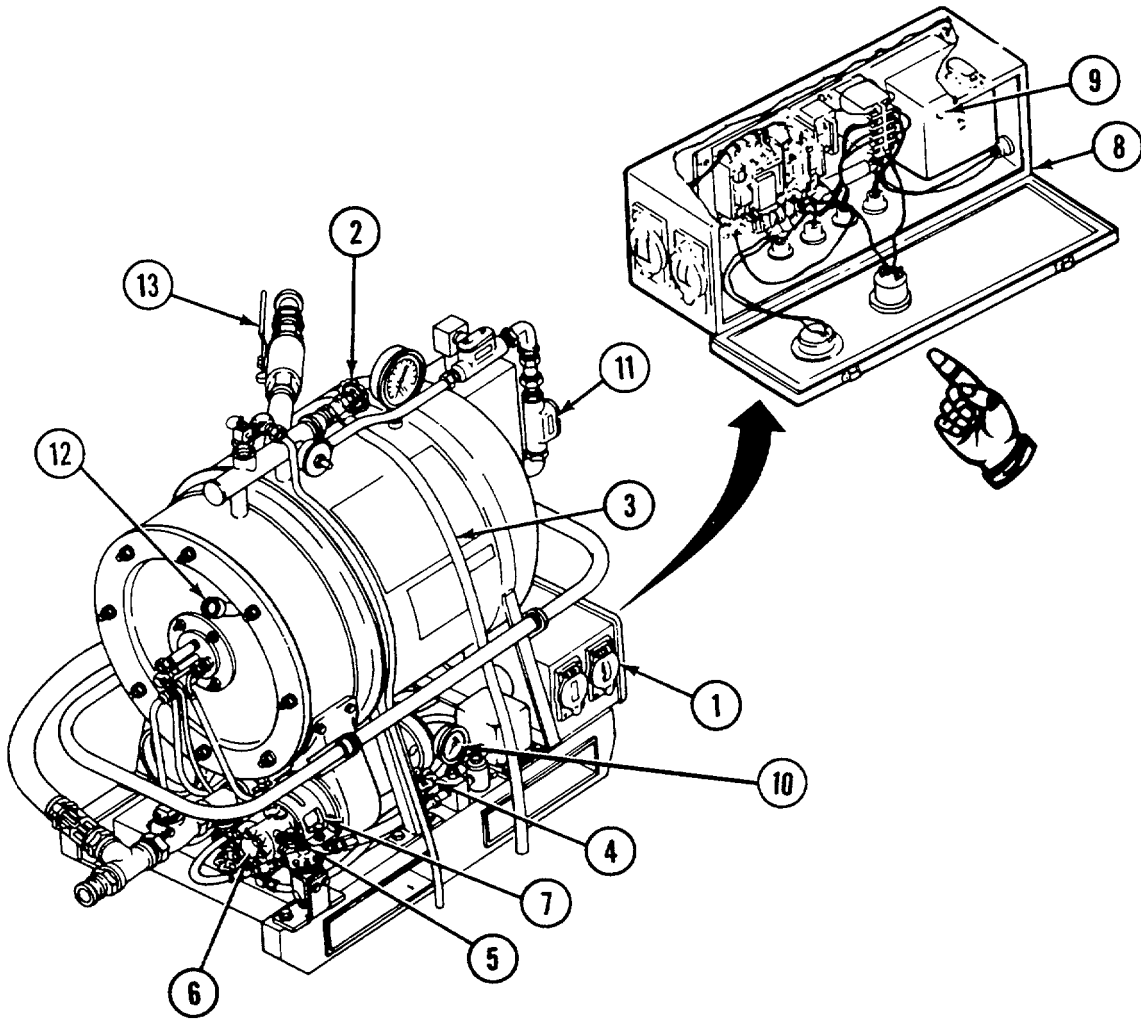

FIGURE 2-19. Water heater controls.

Change 1 2-53

2-8. PREPARATION FOR USE. (CONT)**WARNING**

Use only specified fuel (item 10, app C). Failure to do so may result in death or serious injury to personnel or damage to equipment.

- (5) Remove priming plug (5) and prime fuel pump (6) by pouring fuel into the line. Install priming plug.
- (6) Open air shutter (7) halfway.
- (7) Open the door to control panel (8) and press FLAME SAFEGUARD reset button.
- (9) Close control panel.
- (8) Set water temperature control (11) to the desired setting. (Refer to FM 10-280, Field Laundry Clothing Exchange and Bath Operations, for water temperatures.)
- (9) Place load limit switch (1) to the ON position.

WARNING

Do not touch exhaust ducts while running or immediately after shutdown, as severe burns may result.

NOTE

The water heater burner is equipped with an ultraviolet (UV) scanner and a flame safeguard control unit to purge fumes or vapor from the combustion chamber prior to ignition. The control unit will also cause a safety shutdown if the burner does not ignite within a preset time.

- (10) Check fuel pressure gage (10) for an indication of 75 to 80 psi (517 to 552 kPa). If the pressure gage does not indicate 75 to 80 psi (517 to 552 kPa) within 15 seconds, place load limit switch (1) to the OFF position and repeat steps (1) through (9) until a minimum of 75 to 80 psi (517 to 552 kPa) is indicated on pressure gage (10). After three unsuccessful attempts, notify your supervisor.
- (11) As soon as 75 to 80 psi (517 to 552 kPa) is reached, open fuel shutoff valve (4) one full turn. The burner should ignite within 20 seconds and be visible in sight glass combustion chamber (12). Open valve fully.

2-8. PREPARATION FOR USE. (CONT)

- (12) If the water heater buzzer sounds on the control box, turn off load limit switch (1) and wait approximately two minutes. Repeat steps (1) through (10) to start water heater.
- (13) Adjust air shutter (7) until there is little or no smoke in the heater exhaust.
- (14) When the water reaches the specified temperature (refer to FM 10-280), check temperature gage reading with thermostat setting. The heater flame will shut off automatically and fuel pressure gage (10) will register zero.

Change 1 2-54.1/(2-54.2 blank)

2-8. PREPARATION FOR USE. (CONT)f. Drying Tumbler.

- (1) Set thermostat (1, FIG. 2-20) as follows:
 - (a) For cotton: 250°F (121°C)
 - (b) For wool: 200°F (93°C)
 - (c) For battle dress uniform (BDU's): do not exceed 130°F (54°C).
- (2) Set drying time control (2) to approximately 10 minutes.
- (3) Adjust burner air intake (3) to approximately 1/2 inch (12.7 mm).
- (4) Close fuel shutoff valve (7).
- (5) Loosen three screws (10) on panel door of dryer control panel (5) and open panel door.
- (6) Press reset button (11) on safeguard control unit (12). Close and secure panel door with three screws (10).
- (7) Push start/stop button (4) on dryer control panel (5).
- (8) Check fuel pressure gage (6) for an indication of approximately 100 psi (690 kPa).
- (9) Open fuel shutoff valve (7) one full turn.

NOTE

The dryer burner is equipped with an ultraviolet (UV) scanner and a flame safeguard control unit to purge fumes or vapor from the combustion chamber prior to ignition. The control unit will also cause a safety shutdown if the burner does not ignite within a preset time.

- (10) If dryer warning light (8) lights and beeper (9) sounds on the front of dryer control panel (5) perform the following:
 - (a) Push start/stop button (4) on dryer control panel (5).
 - (b) Loosen three screws (10) on panel door of dryer control panel (5) and open panel door.
 - (c) Wait for approximately 2 minutes after shutdown to allow for the safeguard timer to reset and cool the electrical igniter.
 - (d) Press and release reset button (11) on safeguard control unit (12). Position dryer control panel (5) and secure with three screws (10).
 - (e) Push start button (4) on dryer control panel (5).

2-8. PREPARATION FOR USE. (CONT)

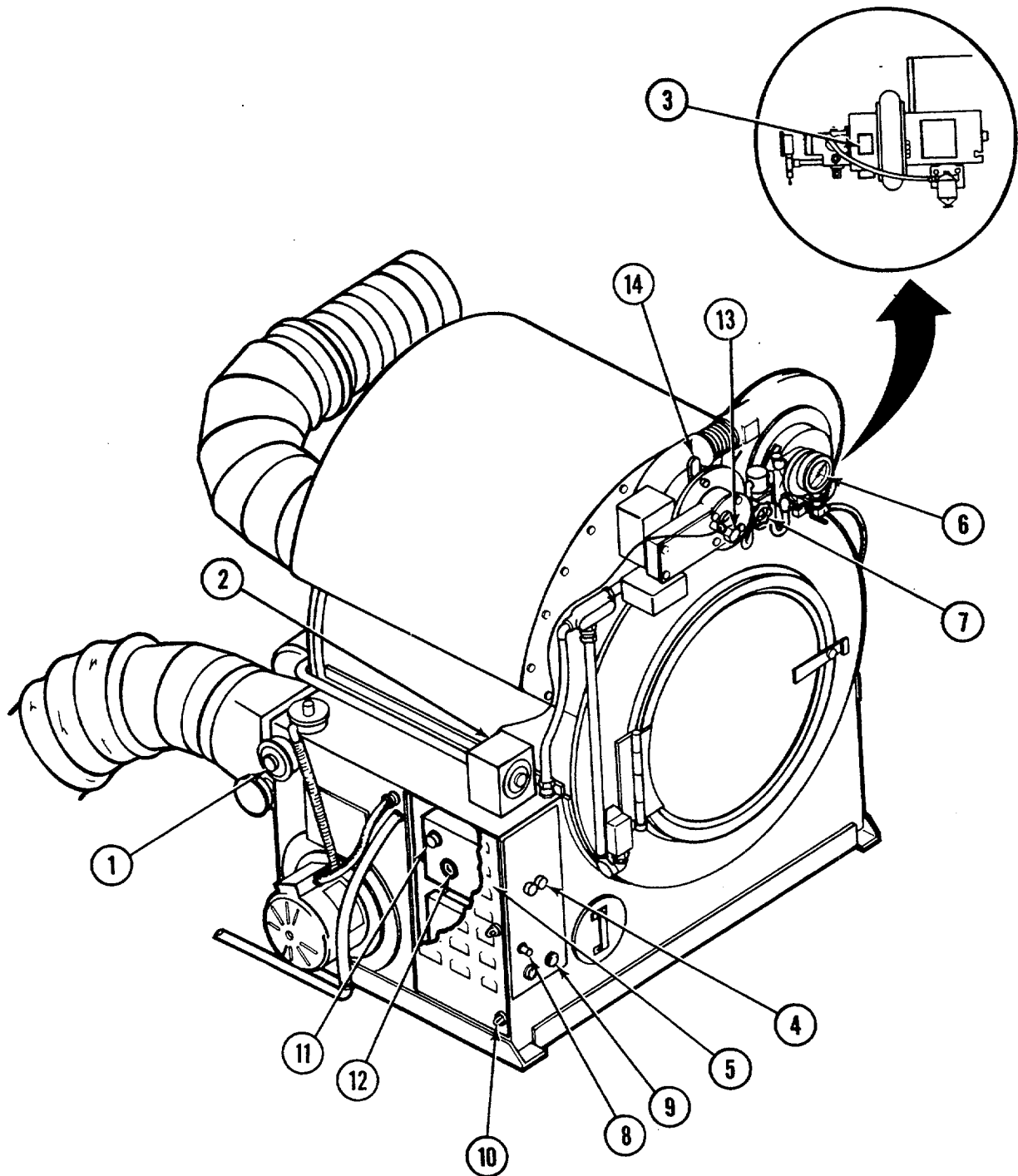

Figure 2-20. Drying tumbler controls .

2-8. PREPARATION FOR USE. (CONT)

- (11) If the burner ignites but does not remain on, adjust burner air intake (3) and repeat steps (5), (6), and (7) until the burner remains on. After two unsuccessful attempts, notify your supervisor.
- (12) After the burner remains on, open fuel shutoff valve (7) fully and adjust air shutter (14) so that the heater burner has a steady roar. A bright, clean flame will be seen in sight glass (13).
- (13) Open dryer door until first load is placed in the dryer. This will prevent excess fuel consumption until the dryer is ready to be used.
- g. Washer Controller. The washer's controller is equipped to use pre-punched formula charts with preset formulas. The formula chart is wrapped around a timer cylinder contained in the controller located beside the machine. The formula is visible to the operator during operation. Marker labels affixed to the formula chart indicate the operation in progress and which supplies are needed when the timer signals. Table 2-2 contains a list of contact finger functions.
- h. Formula Chart.
- (1) If it is necessary to change formulas, remove the formula chart as follows:

WARNING

Do not make or change electrical connections while the unit is in operation. The voltage generated by the engine-generator can cause death by electrocution. Keep moisture away from the engine-generator and keep the surrounding area dry when operating the unit. Failure to observe this warning may result in death by electrocution. Do not service the unit with fuel while the unit is in operation. Failure to observe this warning may result in serious injury or death to personnel.

- (a) Open the control panel door by turning door latch one-half turn to the left.
- (b) With contact fingers (1, FIG. 2-21) locked in place on cylinder (2), turn the cylinder until the fingers are at the start position on formula chart (3).
- (c) Unlock contact fingers (1) from cylinder (2) by pushing contact finger locking bar (4) in slightly. While holding the locking bar in, pull locking clamp (5) up and release the locking bar.
- (d) Pull contact finger locking bar (4) out and up until contact fingers are not in contact with cylinder.
- (1)

Table 2-2. Control Finger Functions

CONTROL FINGER NUMBER	FUNCTION	DESCRIPTION
11	Common	Makes contact with cylinder at all times.
12	ODD Signal 1 - add soap	When finger comes in contact with cylinder, a signal informs operator to add soap.
13	EVEN Signal 2 - add supplies	When finger comes in contact with cylinder, a signal informs operator to add supplies.
14	Drain	When finger breaks contact with cylinder, the drain valve opens and all the water in the cylinder drains from the washer.
15	Hot water	When finger comes in contact with cylinder, hot water enters the cylinder.
16	Cold water	When finger comes in contact with cylinder, cold water enters the cylinder.
17	High/Low water level	When finger comes in contact with cylinder, high water level or low water level selected, depending on the water level position.
18	Extra water	When finger comes in contact with cylinder, extra water enters the cylinder.
19	Blank	
20	Blank	
21	Blank	
22	Blank	
23	Blank	
24	Blank	
25	Blank	

Table 2-2. Control Finger Functions

CONTROL FINGER NUMBER	FUNCTION	DESCRIPTION
26	Blank	
27	Blank	
28	Blank	
29	Blank	
30	Blank	
31	Blank	
32	Blank	

2-8. PREPARATION FOR USE. (CONT)

- (e) Release the end of formula chart (3) attached with spring-loaded clamps (6) by pulling down on the right and left spring-loaded clamps and withdrawing formula chart bar (7).
 - (f) Release the opposite end of formula chart (3) by withdrawing formula chart bar (7) from right and left stationary clamps (8).
 - (g) Carefully remove formula chart (3) from cylinder (2) by pulling outward on the end of the chart that was secured by spring-loaded clamps (6).
- (2) Install formula chart as follows:
- (a) With contact fingers (1, FIG. 2-22) locked in place on cylinder (2), turn the cylinder until the fingers are at the start position on the cylinder.
 - (b) With formula chart (3) held so that the minute markers are in descending order, top to bottom, attach the bottom of the chart to right and left stationary clamps (8).
 - (c) Turn cylinder (2) until formula chart (3) wraps around the cylinder. The right edge of the chart must be even with the right edge of the cylinder.
 - (d) Unlock contact fingers (1) from cylinder (2) by pushing contact finger locking bar (4) in slightly. While holding the locking bar in, pull locking clamp (5) up and release the locking bar.
 - (e) Pull contact finger locking bar (4) up and out and up until contact fingers (1) are not in contact with cylinder (2).

2-8. PREPARATION FOR USE. (CONT)

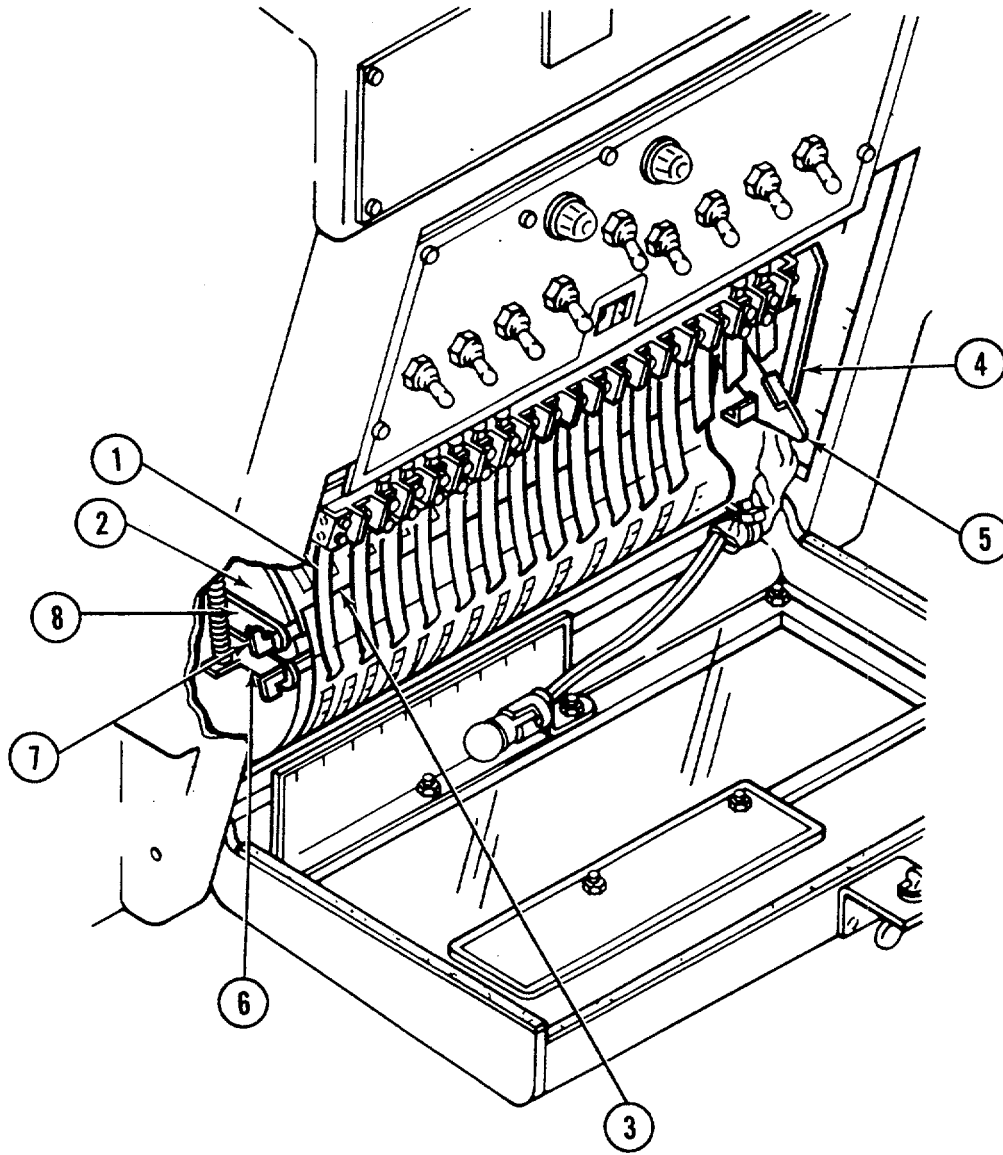

Figure 2-21. Formula chart removal .

2-8. PREPARATION FOR USE. (CONT)

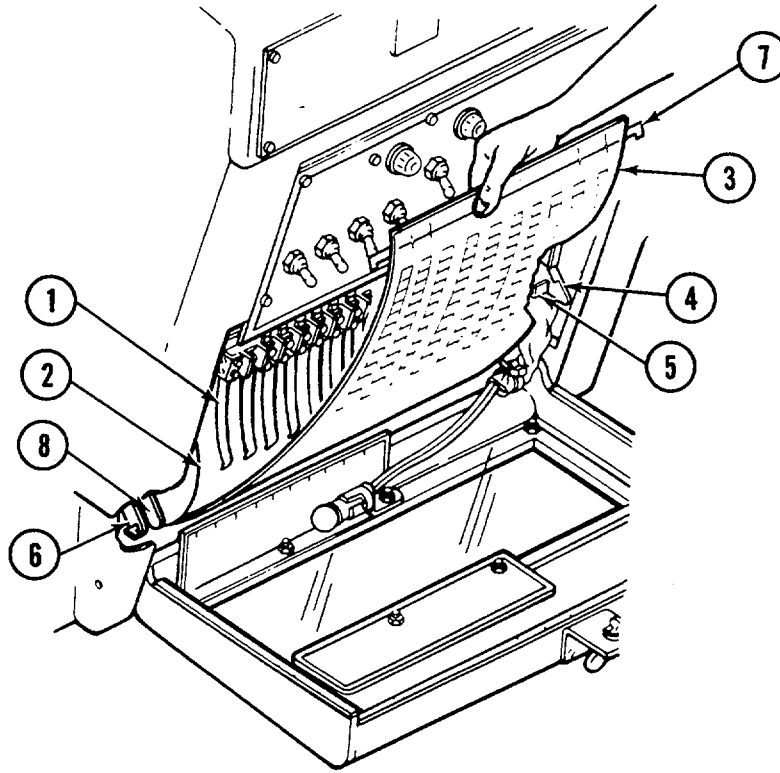

Figure 2-22 . Formula chart replacement .

2-8. PREPARATION FOR USE. (CONT)

- (f) Attach the top of formula chart bar (7) to right and left spring-loaded clamps (6). Ensure clamps are properly connected together.
- (g) Lock contact fingers (1) by pushing contact finger locking bar (4) down and in until locked in place by locking clamp (5).
- (h) Close and secure the control panel door.

2-9. OPERATING PROCEDURES.

- a. Automatic Washing. The following steps are for operating the washer using the automatic timer to control the wash cycle.

WARNING

MASTER switch on the control panel must be OFF while loading/unloading wash or when not in use. The washing machine could be activated, causing serious injury to personnel.

- (1) Load the washer with up to 60 pounds (27.2 kg) of wash. Table 2-3 lists the weight of specific clothing items.
- (2) Check the air tank pressure gage for a pressure of at least 60 psi (414 kPa).

NOTE

When washing camouflage clothing, use warm water and mild detergent. Do not use chlorine bleach or starch on camouflage clothing.

- (3) Add the proper amount of washing supplies through the soap chute. Refer to FM 10-280 for field laundry washing and decontamination formulas.
- (4) Turn control knob (1, FIG. 2-23) until chart fingers are at the START marker on the formula chart.
- (5) Place SIGNAL CANCEL switch (3) to START position and place remaining switches to FORMULA.
- (6) Place master switch (4) to formula position.
- (7) Turn cylinder until interior light (5) on the door comes on. This is the start of the automatic cycle.
- (8) Select desired MOTOR switch (2) position. For normal work, set MOTOR switch to RUNS WHILE DRAINING position.
- (9) When signal light (6) on the controller comes on and buzzer sounds, the operation markers affixed to the formula chart will show what supplies to add.

Table 2-3. List of Weights

Item (One each - medium size)	Dry weight - pounds (kg)	
COLD-DRY STANDARD ENSEMBLE		
CAP, field, pile, M-51	0.45	(0.20)
HOOD, winter, w/fur ruff, M-51	0.85	(0.39)
MITTEN SET, arctic	1.45	(0.66)
MITTEN, inserts, 3-finger.....	0.20	(0.09)
SOCKS, wool, cushion sole.....	0.20	(0.09)
BOOTS, insulated, combat, rubber, white (cold-dry).....	5.00	(2.27)
MUFFLER, wool	0.40	(0.18)
SUSPENDERS, trousers.....	0.25	(0.11)
UNDERSHIRTS, winter, M-1950.....	0.87	(0.39)
DRAWERS, winter, M-1950.....	0.88	(0.40)
TROUSERS, shell, field, M-.....	2.25	(1.02)
LINER, trousers, shell, field, M-51	1.70	(0.77)
SHIRT, field, wool, OG108	1.60	(0.73)
COAT, field, cotton, M-51	3.25	(1.47)
LINER, coat, field, cotton, M-51	2.20	(0.99)
TROUSERS, shell, arctic, M-51	1.12	(0.51)
LINER, trousers, shell, arctic, M-51.....	2.20	(0.99)
PARKA, shell, M-51	2.25	(1.02)
LINER, parka, shell, M-51.....	3.10	(1.41)
MITTENS, overwhite	0.20	(0.09)
PARKA, overwhite.....	1.50	(0.68)
TROUSERS, overwhite	0.90	(0.41)
CHEMICAL PROTECTION		
HOOD, field, protective, M-4	0.60	(0.27)
UNDERSHIRT, cotton, lightweight, special protective.....	0.70	(0.32)
DRAWERS, cotton, lightweight, special protective.....	0.85	(0.39)
COAT (PARKA), vesicant protective.....	1.80	(0.82)
TROUSERS, vesicant protective	0.95	(0.43)
GLOVES, cotton, special (CW protective)	0.35	(0.16)
HOT WEATHER STANDARD ENSEMBLE		
CAP, cotton, utility, OD.....	0.18	(0.08)
SOCKS, wool, cushion sole.....	0.20	(0.09)
UNDERSHIRT, cotton, knit, 1/4 sleeve.....	0.30	(0.14)
DRAWERS, cotton, shorts.....	0.22	(0.10)
TROUSERS, cotton utility, OG 107	1.39	(0.63)
SHIRT, cotton, utility, OG 107	1.35	(0.61)

Table 2-3. List of Weights (Continued)

Item (One each - medium size)	Dry weight - pounds (kg)	
HOSPITAL CLOTHING/LINEN		
SLIPPERS, canvas, pair.....	1.2860	(0.5833)
CAP, operating, surgical, green.....	0.0781	(0.0354)
GOWN, operating, surgical, green.....	1.2600	(0.5715)
TROUSERS, operating, surgical.....	0.7333	(0.3326)
SHIRT, man's, operating.....	0.7167	(0.3251)
ROBE, dress, cord.....	2.2500	(1.0206)
GOWN, operating, surgical, white.....	2.000	(0.9072)
SHEET, bed, cotton, white.....	2.000	(0.9072)
PILLOWCASE, cotton,	4.000	(1.8144)
SHEET, bed, cotton, green.....	2.000	(0.9072)
SHEET, bed, cotton, fitted.....	0.5833	(0.2646)
BLANKET, bed, cotton, white.....	3.3750	(1.5309)
BLANKET, bed, wool, OD.....	4.6667	(2.1168)

2-9. OPERATING PROCEDURES. (CONT)

NOTE

The washer will go through a complete cycle, signaling each time to add supplies and at the end of the washing cycle. The timer will stop during filling until the selected water level is reached.

- (10) When the timer signals, the timer will stop advancing. This ensures that no washing operation in the formula is passed. Add supplies according to formula chart and move the SIGNAL CANCEL switch (3) to the opposite position to continue washing.
 - (11) Set MASTER switch (4) to OFF position at the end of the cycle.
 - (12) Transfer laundry to the pre-extraction bin.
- b. Manual Washing. The control assembly provides complete manual operation. With the MASTER switch in MANUAL position, the MOTOR switch, DRAIN switch, WATER LEVEL switch, and WATER switches may be used to obtain whatever manual operation is desired. The following steps are for manual operation.

CAUTION

Any switch in the FORMULA position during manual washing may cause unwanted operations during the wash and rinse cycles.

- (1) Load the washer with up to 60 pounds (27.2 kg) of wash. Table 2-3 lists the weight of specific clothing items.

2-9. OPERATING PROCEDURES. (CONT)

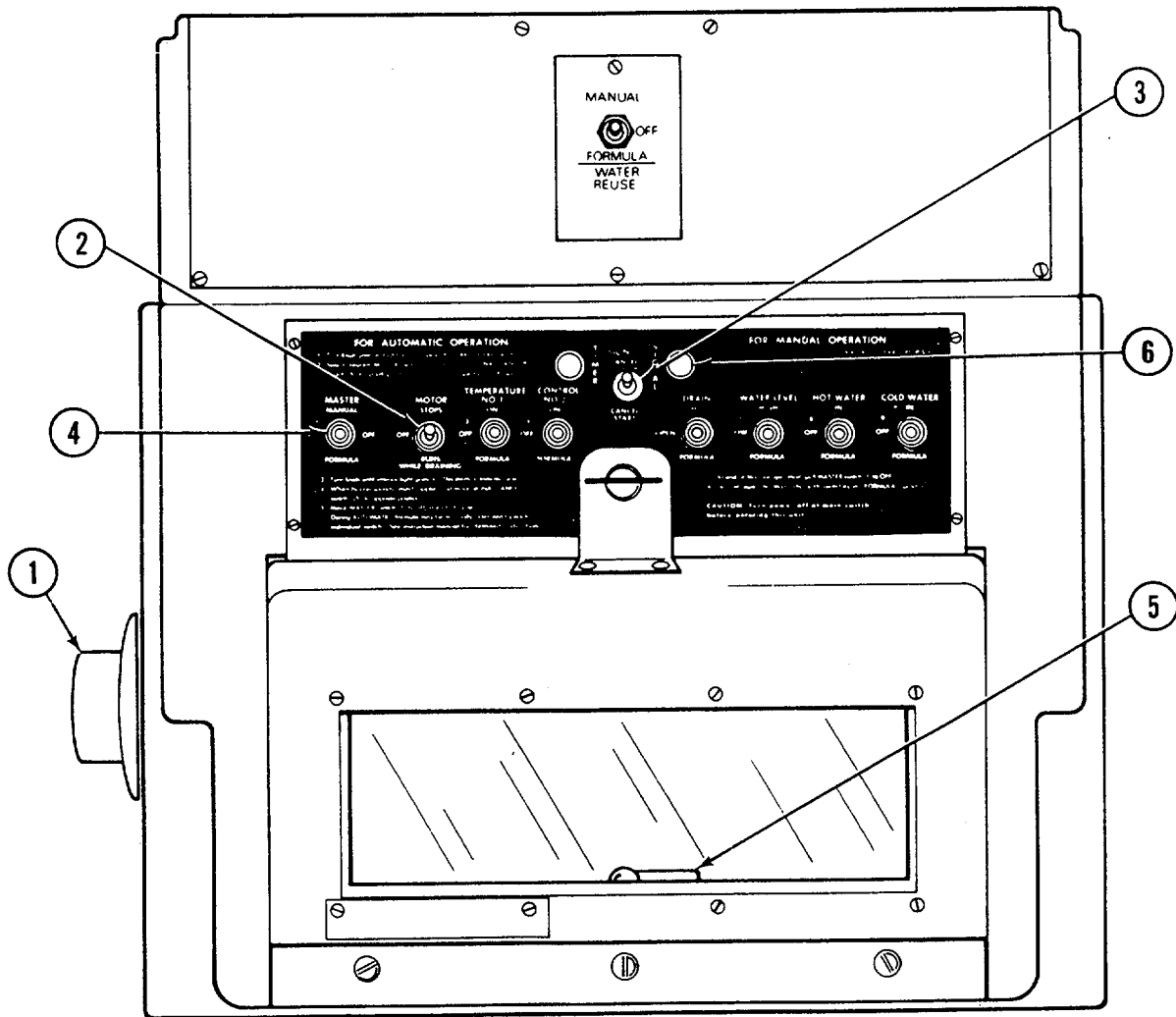

Figure 2-23. Controller .

2-9. OPERATING PROCEDURES. (CONT)

- (2) Select the proper formula from FM 10-280.
- (3) Turn the cylinder to a blank position on the formula chart. In manual operation, first control finger (position 11) must make contact with the cylinder; all remaining contact fingers must not contact the cylinder.
- (4) Check the air tank pressure gage for a pressure of at least 60 psi (414 kPa).

NOTE

Washer will not fill with water if the drain switch is in the open position.

- (5) Select DRAIN, WATER LEVEL, and WATER TEMPERATURE switch positions and MOTOR switch operation as desired.
- (6) Set MASTER switch to MANUAL position and set timer to desired setting. The washer will fill with water to the selected level of the selected temperature.
- (7) Set TIMER ENABLED switch in the down position.
- (8) Add the washing supplies through the soap chute.

NOTE

Washing will continue indefinitely until the DRAIN switch is placed in the OPEN position. The DRAIN switch starts and stops each operation during manual wash.

- (9) When SIGNAL LIGHT lights and buzzer sounds, set TIMER ENABLED switch to cancel position and set DRAIN switch to open position. Wait approximately 1 minute.
- (10) When the machine has drained, the DRAIN switch may be moved to the SHUT position to commence another operation.
- (11) Upon completion of MANUAL operation, set MASTER switch to OFF position.
- (12) Transfer laundry to the pre-extraction bin.

2-9. OPERATING PROCEDURES. (CONT)c. Extracting. (FIG. 2-3)**WARNING**

While extractor basket is spinning, keep hands away. Failure to observe this warning may cause serious injury to personnel.

CAUTION

Do not force extractor lid open. Failure to observe this caution may cause serious damage to equipment.

- (1) Place 30 pounds (13.6 kg) of laundry (approx one-half of a full load) from the pre-extraction bin into the extractor.
- (2) Distribute load evenly around the basket for balance. Ensure articles are completely inside basket.
- (3) Close the extractor lid.
- (4) Pull out EMERGENCY STOP button.
- (5) Set timer to desired setting (normally 3 minutes) and press START button. The lid will lock, the lid lock signal light will come on, and the machine will spin for the set time.
- (6) Emergency stop procedures are as follows:
 - (a) If the machine vibrates excessively or is extremely noisy, or if something is caught between the basket and the curb, push the EMERGENCY STOP button.
 - (b) When the signal light goes out, open the lid and rebalance the load. Ensure nothing has dropped between the basket and the curb.
 - (c) To restart the extractor, pull out the EMERGENCY STOP button, close the lid, and press the START button. When extraction is completed, the basket will stop and the lid lock signal light will go out.

2-9. OPERATING PROCEDURES. (CONT)**WARNING**

While extractor basket is spinning, keep hands away. Failure to observe this warning may cause serious injury to personnel.

- (7) When the lid light goes off, indicating the end of the cycle, press EMERGENCY STOP button.
- (8) Open the lid and transfer the load to the dryer.
- (9) Repeat steps (1) thru (8) for the remainder of the wash load.

d. Drying.**WARNING**

While dryer cylinder is spinning, keep hands away. Failure to observe this warning may cause serious injury to personnel.

- (1) Remove the load from the extractor and place no more than 30 pounds (13.6 kg) in the dryer.
- (2) Close the tumbler door securely.
- (3) Set the temperature control as follows:
 - (a) For cotton: 250° (121°C).
 - (b) For wool: 200°F (93°C).
 - (c) For battle dress uniforms (BDU's): 130°F (54°C).
- (4) Set the drying time to approximately 10 minutes.
- (5) Press start button on dryer.
- (6) When the beeper sounds, turn timer off, open dryer door, and check laundry for dryness.
- (7) If laundry is dry, remove. If laundry is not dry, repeat steps (4) and (5) using a 3-minute drying cycle until laundry is dry.
- (8) Remove laundry from dryer and place in dryer bin.

2-9. OPERATING PROCEDURES. (CONT)e. Shutdown Procedures**NOTE**

The laundry unit may begin to be shut down while the last load of wash is being dried.

- (1) Make certain that all washer control panel switches are in the OFF position.
- (2) Turn off air compressor circuit breaker (3, FIG. 2-7) at the power distribution panel.
- (3) Turn water temperature control (6, FIG. 2-4) to OFF (-180C). Allow the water heater to operate for 2 minutes so that the blower may purge vaporized fuel from the burner. Turn ON/OFF switch (7) to the OFF position and close fuel shutoff valve (9).
- (4) Turn off start switch (1, FIG. 2-6) on the water pump.
- (5) Turn dryer temperature control (9, FIG. 2-2) to OFF (-180C). Allow the dryer to operate for 2 minutes so that the blower may purge vaporized fuel from the burner. Press the stop button (5) and close fuel shutoff valve (12).
- (6) Open the dryer door and allow the dryer to cool for 3 to 5 minutes.
- (7) Set all circuit breakers on the power distribution box to off (FIG. 2-7).
- (8) Refer to TM 5-6115-585-12 and shut down the generator set.

2-10. PREPARATION FOR MOVEMENT.

- a. Perform shutdown operations. (Refer to para 2-9e.)
- b. Remove tarp, two struts, and workstand support brackets from the hose basket and set aside.

WARNING

Use extreme care to avoid spilling fuel. Fuel is highly flammable and may explode if exposed to heat or spark. Clean up spills as soon as possible. Failure to observe this warning may result in death or serious injury to personnel.

- c. Disconnect and drain back into fuel source four fuel lines going to the dryer and water heater. Store fuel lines in hose basket.
- d. Remove the drum fill adapters from the fuel source and store in hose baskets.

2-10. PREPARATION FOR MOVEMENT. (CONT)

- e. Disconnect water pump power cable and store in hose baskets.

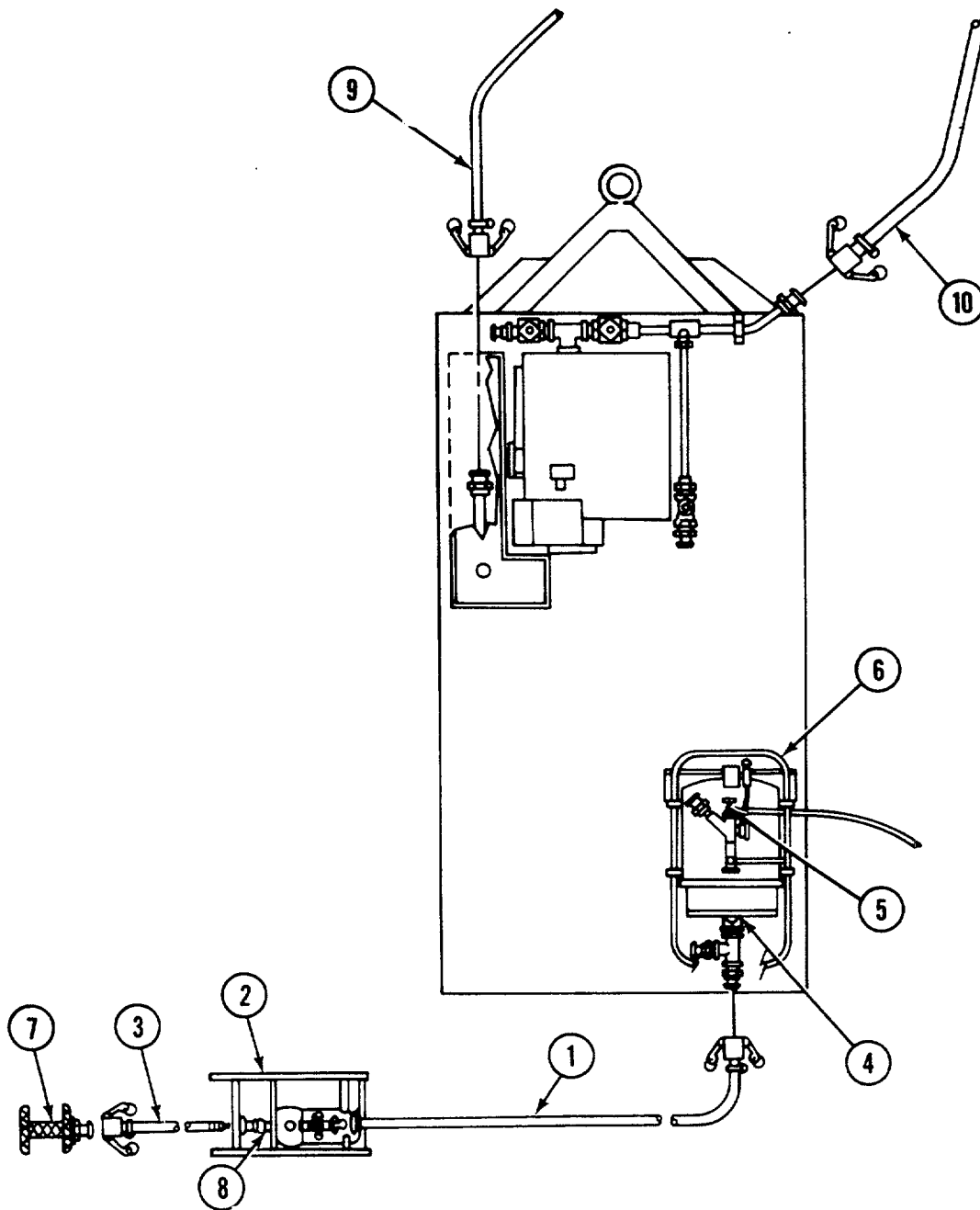

CAUTION

Water in pipes and equipment can freeze during cold weather causing severe damage to equipment. Ensure that water is drained from pumps, lines, and equipment.

- f. Disconnect and drain discharge hose (1) from water pump (2) and store hose in hose baskets.

2-10. PREPARATION FOR MOVEMENT. (CONT)

WARNING

Check that bleeder valve hose is installed on bleeder valve before valve is opened. Serious injury to personnel can occur from hot water.

- g. Disconnect and drain suction hose (3) from water pump (2). Connect long garden hose to water release valve (4). Open water release valve (4) and bleeder valve (5) on water heater (6) and drain water from water heater. Disconnect and store long garden hose in hose basket assemblies.
- h. Disconnect strainer (7) from suction hose (3). Store hose and strainer in hose baskets.
- i. Open petcock valve (8) and drain water from water pump (2).
- j. Store and secure water pump (2) in transport position.
- k. Disconnect and drain pre-extraction bin drain hose (9) and washer drain hose (10). Store hoses in hose baskets.

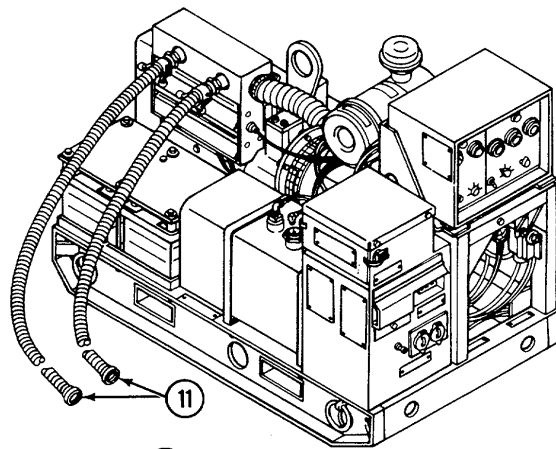

WARNING

Hot exhaust ducts. Allow ducts to cool before disconnecting. Failure to do so will cause burns.

- l. Disconnect and store generator exhaust ducts (11) in hose baskets.
- m. Disconnect dryer lint duct (12) and store inside dryer cylinder (13).
- n. Disconnect exhaust duct (14) from dryer. Store and secure duct on trailer assembly.

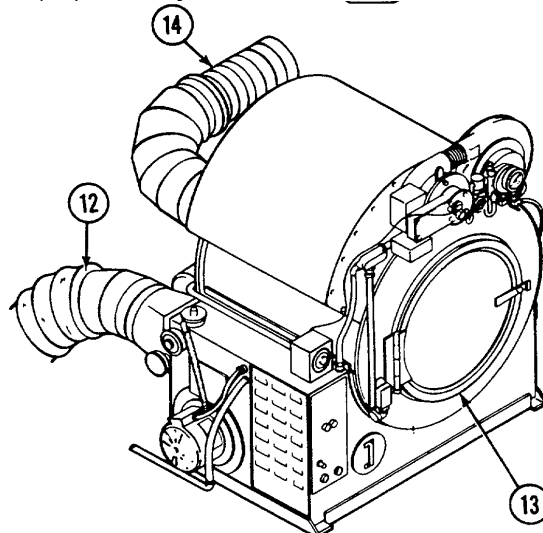

2-10. PREPARATION FOR MOVEMENT. (CONT)

- o. Disconnect two exhaust ducts (15) from water heater and store in hose baskets.

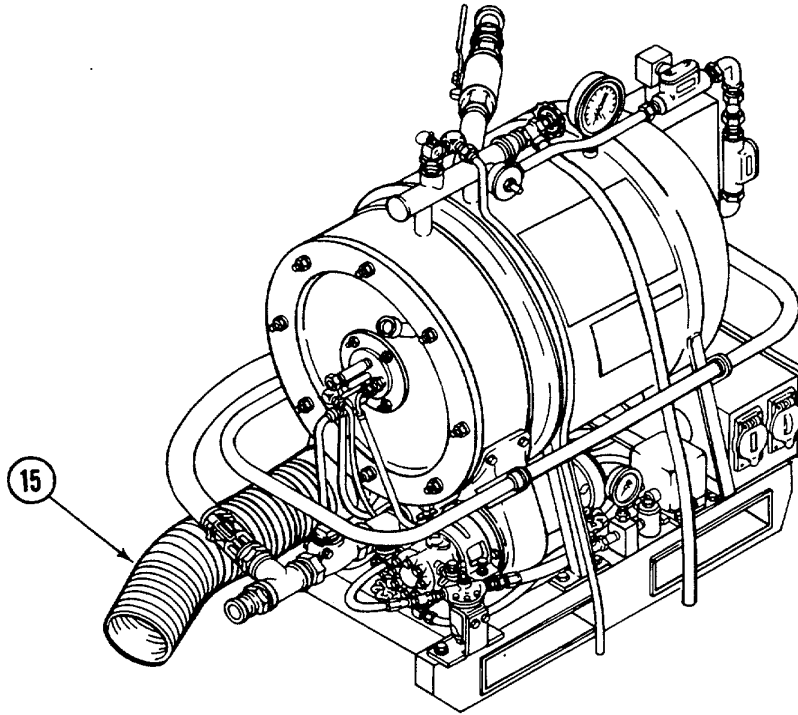

- p. Store and secure dry clothes bin in transport position.
- q. Disconnect power cable from external source (if used) and from power distribution box.
- r. Install support packing between extractor basket and curb.
- s. Ensure all equipment panels and doors are closed.
- t. Disconnect and store ground rod assembly in hose baskets.
- u. Secure all items in hose baskets by fastening straps.
- v. Remove left beam assembly from underneath trailer and store on frame assembly.
- w. Install and secure two struts on center and left beams.
- x. Store and secure ladder on struts.

2-10. PREPARATION FOR MOVEMENT. (CONT)

- y. Disassemble platform assembly and store on trailer.

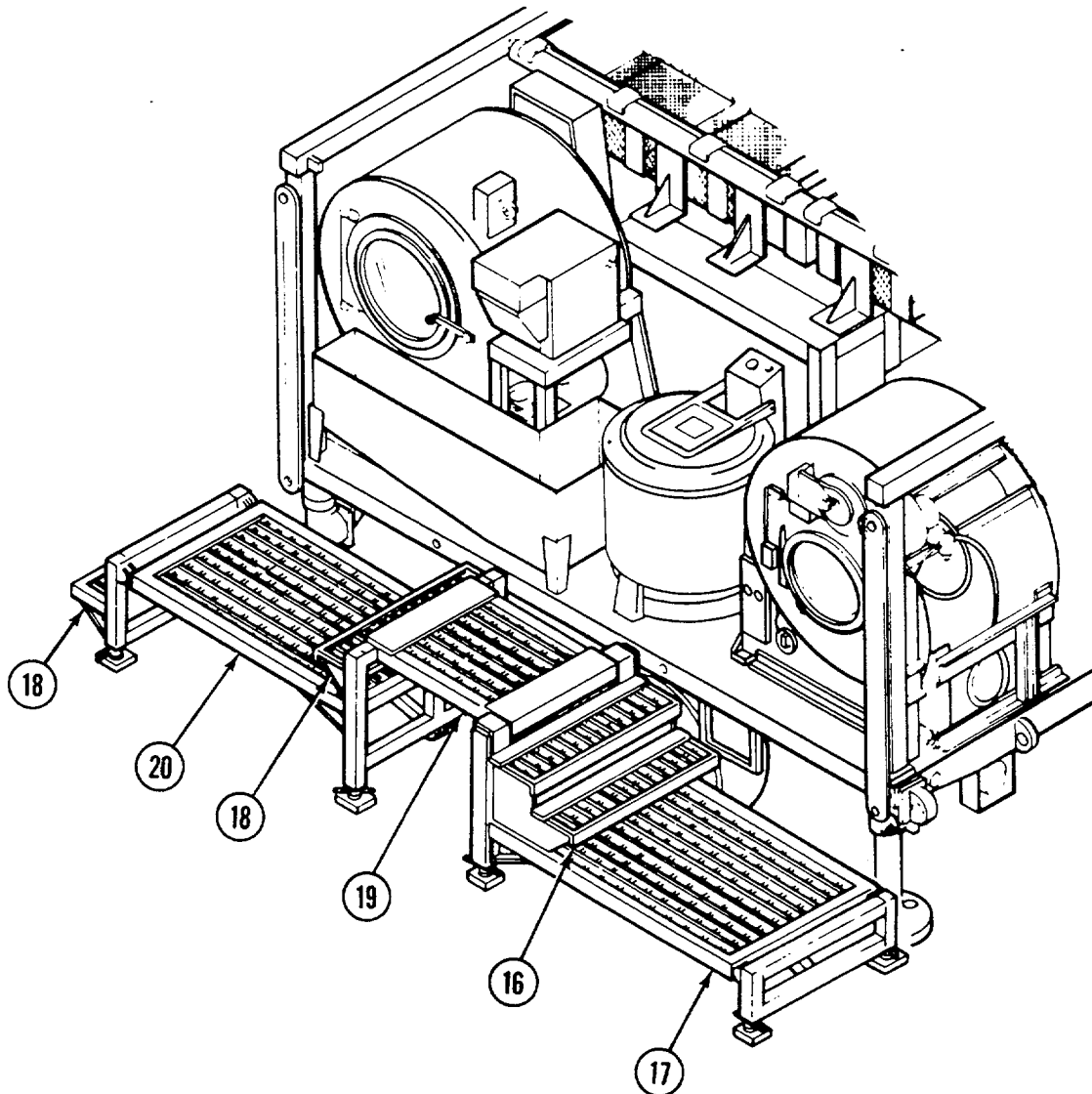

- (1) Remove step (16) from dryer platform (17). Place step behind control stand.
- (2) Remove two steps (18) and store steps in pre-extraction bin.
- (3) Remove short platform (19) from washer platform (20) and dryer platform (17).

2-10. PREPARATION FOR MOVEMENT. (CONT)

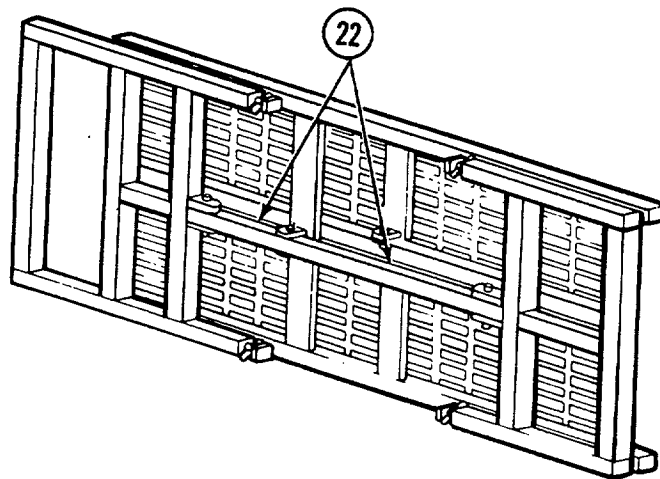
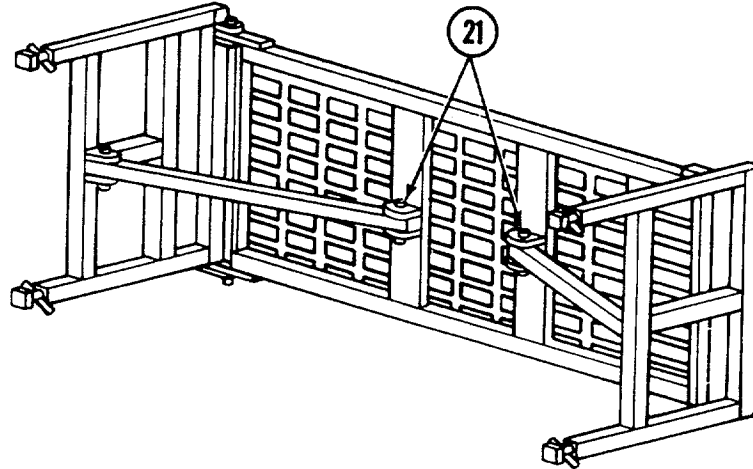

- (4) Remove ball locking pins (21) from washer platform. Adjust stabilizer bars (22) and insert ball locking pins in holes provided.
- (5) Repeat step (4) for dryer platform assembly.

2-10. PREPARATION FOR MOVEMENT. (CONT)

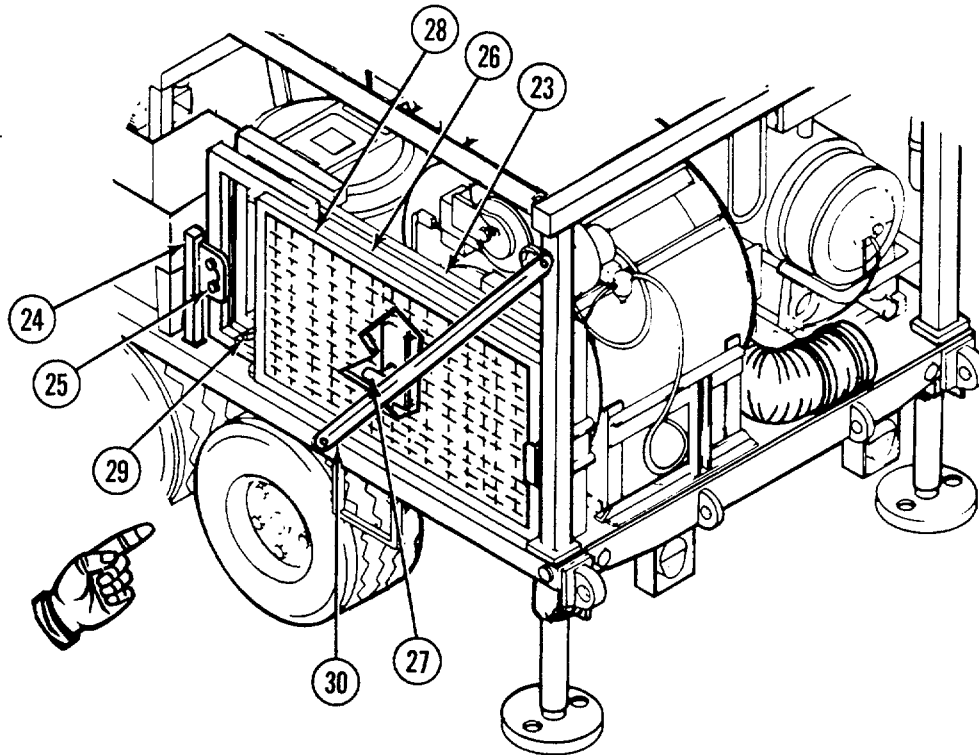

- (6) Place dryer platform assembly (23) on trailer assembly and slide platform toward rear of trailer.
 - (7) Install workstand storage support brace (24) on trailer assembly.
 - (8) Install ball locking pin (25) through dryer platform assembly (23) and workstand storage support brace (24).
 - (9) Install short platform assembly (26) on trailer assembly and secure short platform assembly to dryer platform assembly (23) with clamp (27).
 - (10) Repeat procedures in steps (6), (7), and (8) for washer platform assembly (28).
 - (11) Secure dryer and washer platform assemblies (23) and (28) to trailer assembly with clamp (29).
- z. Secure two transportation braces (30) to frame and trailer assembly.
 - aa. Cover laundry unit with tarp and secure tiedown ropes to trailer.
 - ab. Hitch laundry unit to towing vehicle, release handbrake, raise trailer supports, and remove wheel chocks. Refer to TM 9-2830-276-14&P.

2-11. OPERATING INSTRUCTION ON DECALS AND INSTRUCTION PLATES .

FIGURE 2-24 shows the location and wording of the M85 laundry unit decals and operator caution and warning plates. Refer to the appropriate TM's for trailer and generator data plates.

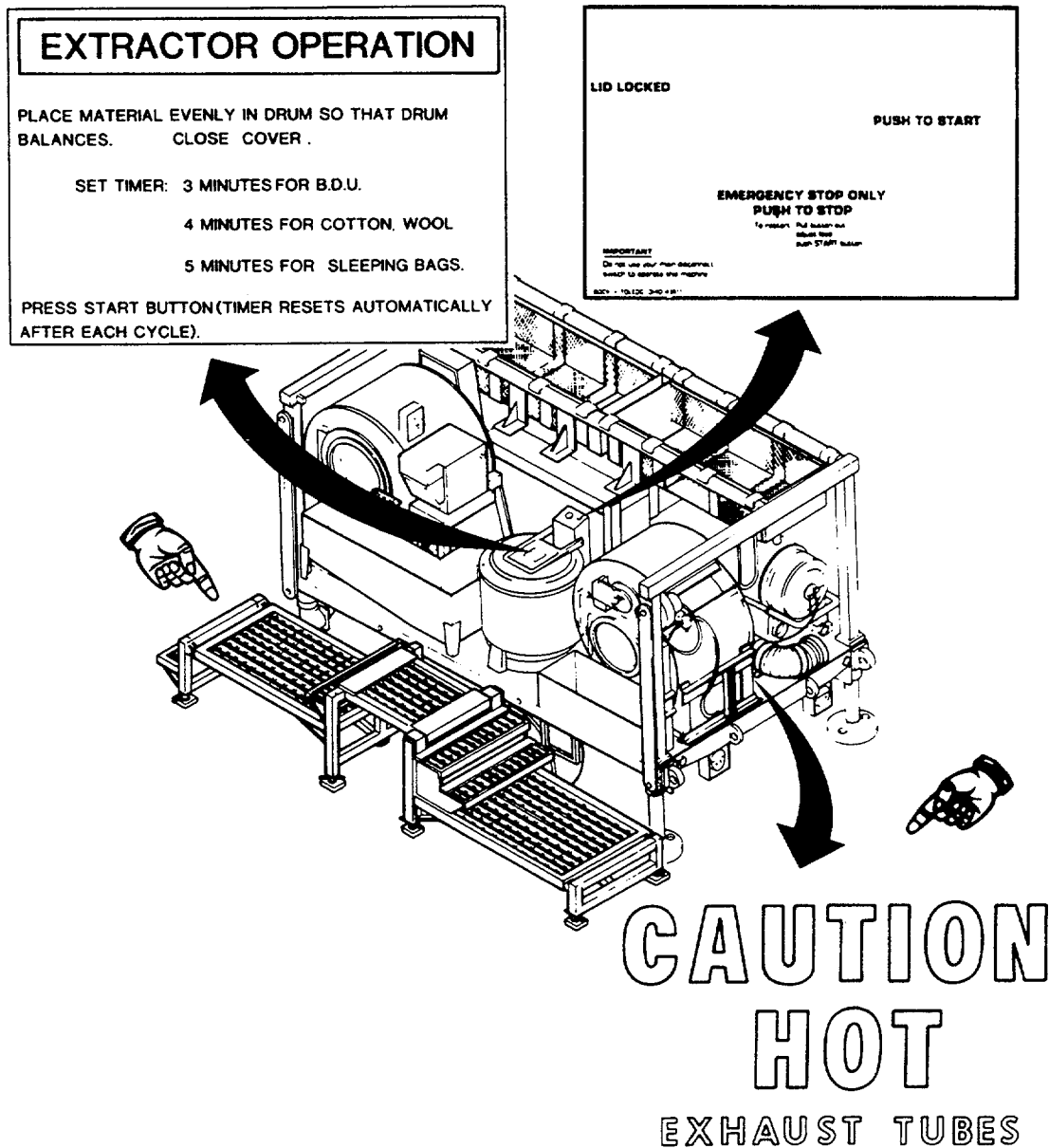

FIGURE 2-24. Operating instructions on decals and plates.
 (sheet 1 of 4)

2-11. OPERATING INSTRUCTION ON DECALS AND INSTRUCTION PLATES. (CONT)

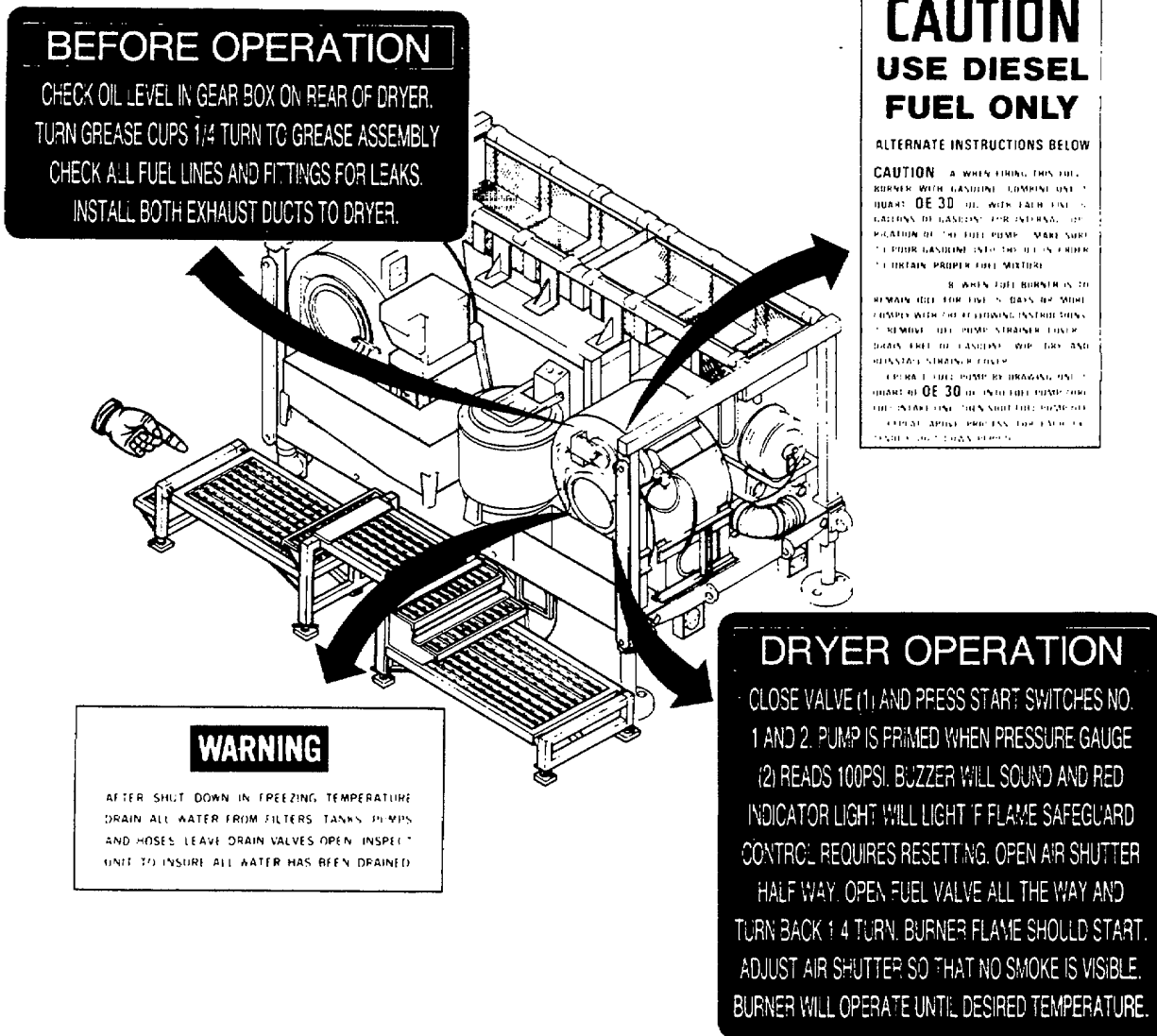

FIGURE 2-24. Operating instructions on decals and plates. (sheet 2 of 4)

2-11. OPERATING INSTRUCTION ON DECALS AND INSTRUCTION PLATES.(CONT)

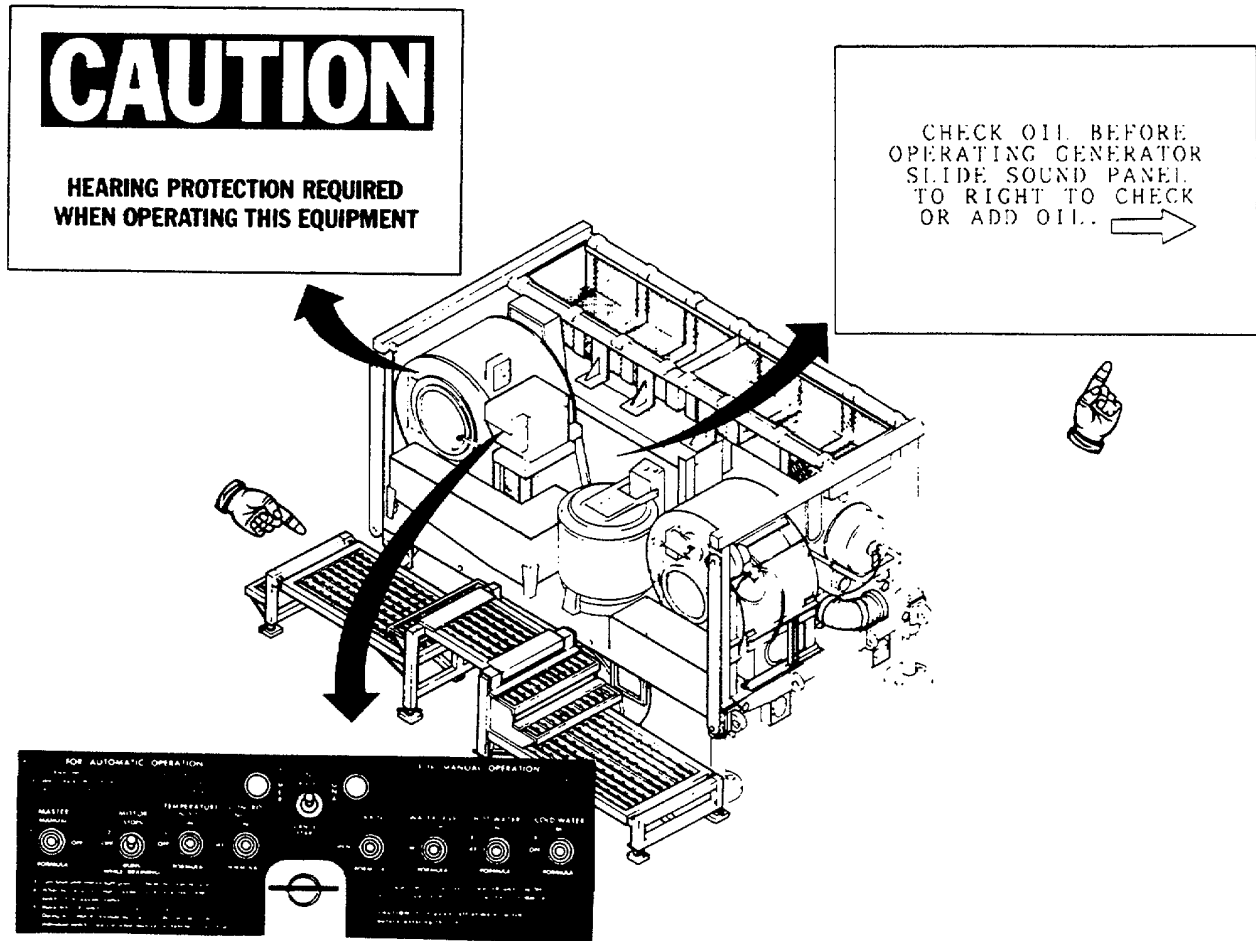

FIGURE 2-24. Operating instructions on decals and plates.
(sheet 3 of 4)

Change 1 2-76

2-11. OPERATING INSTRUCTION ON DECALS AND INSTRUCTION PLATES.(CONT)

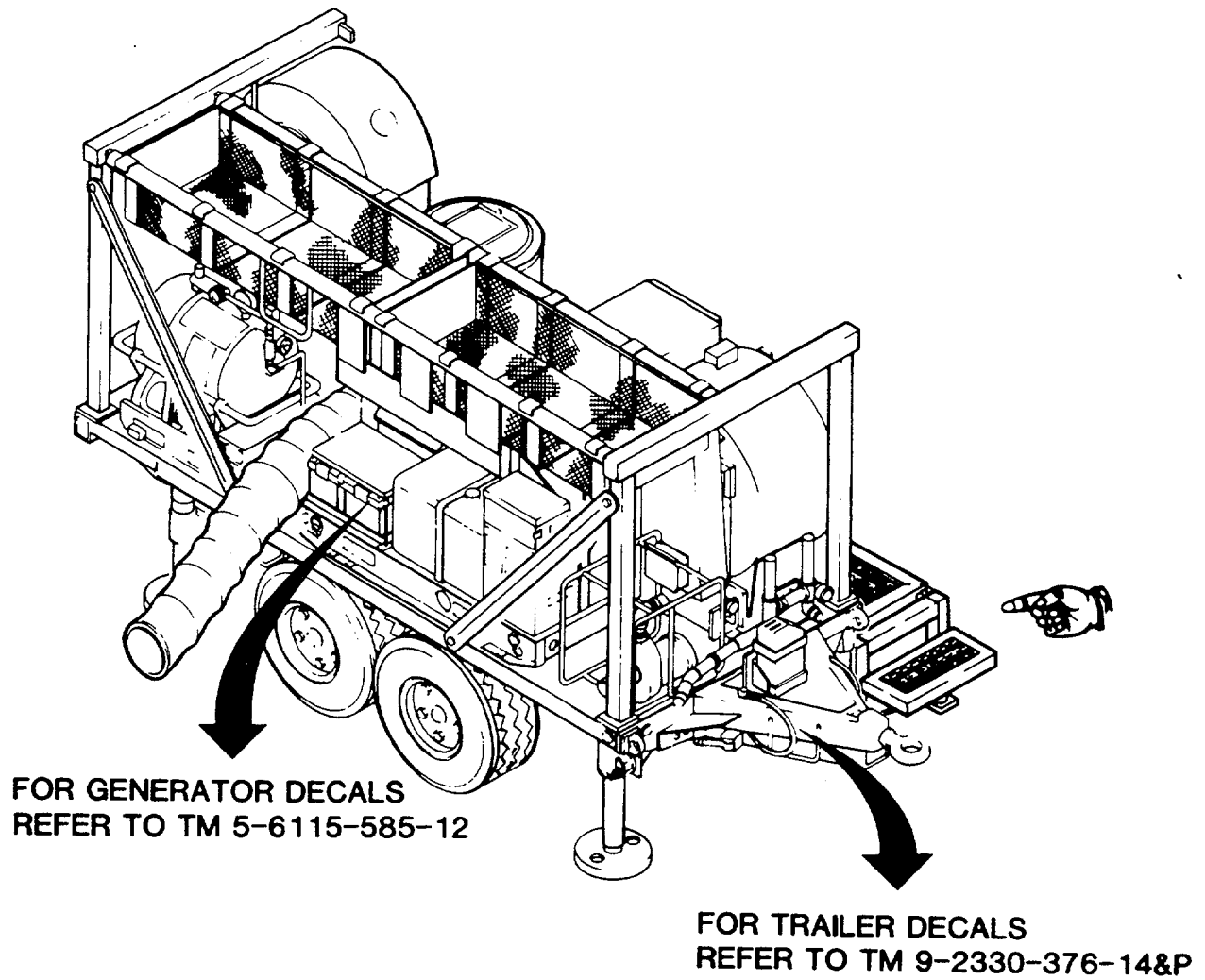

FIGURE 2-24. Operating instructions on decals and plates.
(sheet 4 of 4)

Change 1 2-77

Section IV. OPERATION UNDER UNUSUAL CONDITIONS

Para	Title	Page
2-12	Operation in Extreme Cold.....	2-78
2-13	Operation in Dust or Sand.....	2-79
2-14	Operation in Snow and Mud.....	2-79
2-15	Operation in Saltwater Areas	2-79
2-16	Emergency Procedures.....	2-79

2-12. OPERATION IN EXTREME COLD (BELOW 0°F or -18°C)

WARNING

Do not touch cold metal parts with bare hands. Cold metal parts can cause frostbite and injury to personnel.

CAUTION

Subzero temperatures cause rubber and metal parts to become brittle and prone to breakage. Use proper lubrication for extreme cold operations.

- a. Lubrication of Generator Set. Refer to TM 5-6115-585-12 for proper lubrication in extreme cold (below 0°F or -18°C).
- b. Lubrication of Laundry Unit. Ensure the laundry unit has been lubricated in accordance with LO 10-3510-209-12 for the air temperature expected.
- c. Operation in Extreme Cold. During operation in extreme cold, steps must be taken to protect the equipment from freezing. Operate the unit inside a tent or other suitable enclosure if necessary. Water must be supplied without exposing the water pump or water hose to below-freezing temperatures. After operation in extreme cold, perform the following:
 - (1) Shut down and drain water heater and water pump (refer to para 2-9e).
 - (2) Disconnect and drain hoses (refer to para 2-10).
 - (3) With the washer and compressor operating, switch the hot water and cold water switches on the controller to manual position, with drain switch open and master switch at manual. Allow 2 minutes to drain all water from the washer.
 - (4) Open the drain valve under the compressor air supply tank and drain condensation.
 - (5) Load the trailer and store it in a heated shelter if possible.

2-13. OPERATION IN DUST OR SAND.

- a. Lubricate the equipment in accordance with the LO 10-3510-209-12.

WARNING

Compressed air used for cleaning purposes will not exceed 30 psi (207 kPa). Use only with effective chip-guarding and personal-protective equipment (goggles, shield, gloves, etc.).

- b. If possible, shut down the unit during severe dust storms and cover it with a tarpaulin or other suitable protective covering. When the area is reasonably clear of dust, clean the unit thoroughly. Use dry compressed air to clean hard-to-reach places.

2-14. OPERATION IN SNOW AND MUD.

Take necessary precautions to ensure a firm footing for the platform by using a field-expedient blocking underneath the platform pads.

2-15. OPERATION IN SALTWATER AREAS.

- a. Inspect the laundry unit frequently for rust and corrosion. Rusted or corroded condition must be corrected immediately. If rust or corrosion is present, notify your supervisor.

CAUTION

Do not direct high-pressure water hose nozzles or steam cleaner nozzles into electrical connections/junction boxes.

- b. Frequently wash the laundry unit to prevent a buildup of salt deposits.

2-16 EMERGENCY PROCEDURES.

CAUTION

Lack of lubrication may cause pump damage when straight gasoline is used as fuel. To avoid failure, 1 quart (0.9 liter) of oil must be mixed with each 5 gallons (19 liters) of gasoline used.

- a. The laundry unit is designed to operate on diesel fuel. Under emergency conditions the dryer and water heater may be fueled with gasoline (item 11, app C). When using gasoline as the fuel source, 1 quart of OE-30 weight oil (item 13, app C) must be added to 5 gallons of gasoline.
- b. There is no alternative fuel source for the generator.

2-79/(2-80 blank)

CHAPTER 3
MAINTENANCE INSTRUCTIONS

Section I. LUBRICATING INSTRUCTIONS

Para	Title	Page
3-1	Laundry Unit Lubrication.....	3-1
3-2	Generator Lubrication.....	3-1
3-3	Trailer Lubrication.....	3-1

3-1. LAUNDRY UNIT LUBRICATION.

Refer to LO 10-3510-209-12 for operator lubrication of the M85 Laundry Unit.

3-2. GENERATOR LUBRICATION.

Refer to LO 5-6115-585-12 for lubrication instructions on the 10-kW generator.

3-3. TRAILER LUBRICATION.

Refer to TM 9-2330-376-14&P for lubrication instructions on the trailer.

Section II. TROUBLESHOOTING PROCEDURES

Para	Title	Page
3-4	Introduction	3-1
3-5	Troubleshooting.....	3-1

3-4. INTRODUCTION.

- a. Table 3-1 lists the common malfunctions which you may find during operation or maintenance of the laundry unit or its components. You should perform tests/inspections and corrective actions in the order listed.
- b. This manual cannot list all malfunctions that may occur nor all tests or inspections and corrective actions. If a malfunction is not listed or is not corrected by listed corrective actions, notify your supervisor.

3-5. TROUBLESHOOTING.

Use the symptom index in table 3-1 for quick access to troubleshooting procedures in table 3-2.

Table 3-1. Symptom Index

Symptom	Troubleshooting Procedure Page
1. Water pump fails to deliver water.....	3-2
2. Water heater and dryer fail to start.....	3-3
3. Flame fails in burner (water heater/dryer).....	3-5
5. Fuel pressure too low or fuel pressure pulsates (water heater/dryer).....	3-6
6. Fuel pump fails to deliver fuel to burner (water heater/dryer).....	3-7
7. Black smoke comes out of burner exhaust duct (water heater/dryer).....	3-8
8. Extractor fails to start	3-8
9. Extractor basket fails to turn.....	3-9
10. Extractor fails to drain	3-9
11. Washer fails to fill with water.....	3-9
12. Washer fills with wrong amount of water.....	3-10
13. Washer fills with wrong temperature of water	3-10
14. Washer fails to tumble	3-11
15. Washer fails to drain	3-12

Table 3-2. Troubleshooting

MALFUNCTION
TEST OR INSPECTION
CORRECTIVE ACTION

1. WATER PUMP FAILS TO DELIVER WATER.

- Step 1. Check that electrical power is available and properly connected to water pump.
 - a. If no power is available, report problem to unit maintenance.
 - b. If power is available, proceed to next step.
- Step 2. Check water pump motor for reversed rotation.
 - a. Set ON/OFF Switch to ON. Inspect motor for correct rotation. Motor should rotate in direction of arrow.
 - b. If rotation is incorrect, check all other motors on laundry unit for proper rotation. If all motors are rotating backwards, shut down power and reverse any two phase leads (L1, L2, L3) at the generator connection.
 - c. If some (but not all) motors are rotating backwards, notify your supervisor.
 - d. If motor is rotating in proper direction, proceed to next step.

Table 3-2. Troubleshooting (Continued)

MALFUNCTION	TEST OR INSPECTION	CORRECTIVE ACTION
1. WATER PUMP FAILS TO DELIVER WATER. (Cont)		
Step 3.	Check pump to verify that it has been adequately primed.	
	a.	If pump is not primed, refer to paragraph 2-8c and prime the pump.
	b.	If pump has been adequately primed, proceed to step 4.
Step 4.	Check water source to see if it is too shallow.	
	a.	If water source is too shallow, remove suction hose and place it in deeper water. Refer to FM 10-280.
	b.	If water source is not too shallow, proceed to step 5.
Step 5.	Check suction hose and strainer for clogs.	
	a.	If suction hose is clogged, remove and clean suction strainer.
	b.	If suction hose is not clogged, proceed to step 6.
Step 6.	Check hose assemblies for air leaks.	
	a.	If air leaks are present, repair or replace hose assemblies. Repair hose assembly by tightening hose clamps.
	b.	If air leaks are not present and problem persists, notify your supervisor.
2. WATER HEATER AND DRYER FAIL TO START.		
Step 1.	Check to see if flame safeguard control lockout switch is tripped.	
	a.	If switch is tripped, refer to paragraph 2-8e(8) for the dryer and paragraph 2-8d(6) for the water heater and reset flame safeguard control lockout switch.
	b.	If switch is not tripped, proceed to next step.
Step 1.1.	Check to see if three circuit breakers inside of control panel are tripped.	
	a.	If circuit breakers are tripped, reset circuit breakers by pushing them in.
	b.	If circuit breakers are not tripped and dryer still fails to start, proceed to next step.
Step 2.	Check that water temperature thermostat on the water heater is set high enough to start the water heater.	
	a.	If thermostat setting is not high enough, increase thermostat setting.
	b.	If water heater still does not start, proceed to next step.

Table 3-2. Troubleshooting (Continued)

MALFUNCTION	TEST OR INSPECTION	CORRECTIVE ACTION
2. WATER HEATER AND DRYER FAIL TO START. (Cont)		
Step 3.	Check water supply in water heater tank.	<ul style="list-style-type: none"> a. If water supply is low, fill water heater tank with water. b. If water heater tank is full, proceed to next step.
Step 4.	Check to see if load limit switch is tripped.	<ul style="list-style-type: none"> a. If switch is tripped, move switch to OFF for 10 seconds, then to ON. b. If switch is not tripped, proceed to next step.
Step 5.	Check that electrical power is available to dryer and water heater. Check circuit breakers on power distribution panel.	<ul style="list-style-type: none"> a. If no power is available, report problem to your supervisor. b. If power is available, proceed to next step.
Step 6.	Check to see if blower motor reset button is tripped.	<ul style="list-style-type: none"> a. If button is tripped, reset blower motor reset button. b. If reset button is not tripped, notify your supervisor.

3. FLAME FAILS IN BURNER (WATER HEATER/DRYER).**WARNING**

Fuel is very flammable and can explode easily. To avoid serious injury or death, keep fuel away from open fire and keep fire extinguisher within easy reach when working with fuel. Do not work on fuel system when burner is hot. Fuel can be ignited by hot burner. Shut off engine and do not smoke while refueling.

- Step 1. Check fuel supply in fuel drum.
 - a. If fuel supply is low, fill fuel drum.
 - b. If fuel supply is adequate, proceed to next step.

Table 3-2. Troubleshooting (Continued)

MALFUNCTION	TEST OR INSPECTION	CORRECTIVE ACTION
3. FLAME FAILS IN BURNER (WATER HEATER/DRYER). (Cont)		
Step 2.	Inspect fuel hose for air leaks.	<ul style="list-style-type: none"> a. If leaks are present, tighten fuel hose connections. b. If no leaks are present, proceed to next step.
Step 3.	Check feed and return fuel hose assemblies to see if they are reversed.	<ul style="list-style-type: none"> a. If feed and return fuel hoses are reversed, disconnect and reconnect fuel hose assemblies in correct positions. b. If feed and return fuel hoses are in correct positions, proceed to next step.
Step 4.	Check fuel pump to verify that it has been primed.	<ul style="list-style-type: none"> a. If fuel pump has not been primed, refer to paragraph 2-8d and prime pump. b. If fuel pump has been primed, proceed to next step.
Step 5.	Check to see if flame safeguard switch is tripped.	<ul style="list-style-type: none"> a. If flame safeguard switch is tripped, refer to paragraph 2-8e for the dryer and paragraph 2-8d for the water heater and reset flame safeguard switch. b. If switch is not tripped, proceed to next step.
Step 6.	Check ignition cable assemblies for loose connections at electrode and transformer ends.	<ul style="list-style-type: none"> a. If connections are loose, tighten connections at electrode and transformer ends. b. If connections are not loose, notify your supervisor.

4. FUEL PRESSURE TOO HIGH (WATER HEATER/DRYER).

Check fuel pressure gage on the water heater for an indication of 80 psi (552 kPa) and the dryer for over 100 psi (690 kPa).

If gages indicate more than the specified amounts, notify your supervisor.

Table 3-2. Troubleshooting (Continued)

MALFUNCTION	TEST OR INSPECTION	CORRECTIVE ACTION
-------------	--------------------	-------------------

5. FUEL PRESSURE TOO LOW OR FUEL PRESSURE PULSATES (WATER HEATER/DRYER).

WARNING

Fuel is very flammable and can explode easily. To avoid serious injury or death, keep fuel away from open fire and keep fire extinguisher within easy reach when working with fuel. Do not work on fuel system when burner is hot. Fuel can be ignited by hot burner. Shut off engine and do not smoke while refueling.

- Step 1. Check fuel supply in fuel drum.
- a. If fuel supply is low, fill-fuel drum.
 - b. If fuel supply is adequate, proceed to next step.
- Step 2. Inspect fuel hose for air leaks.
- a. If leaks are present, tighten fuel hose connections.
 - b. If no leaks are present, proceed to next step.
- Step 3. Check feed and return fuel hose assemblies to see if they are reversed.
- a. If feed and return fuel hoses are reversed, disconnect and reconnect fuel hose assemblies in correct positions.
 - b. If feed and return fuel hoses are in correct position, proceed to next step.
- Step 4. Check fuel pump to verify that it has been primed.
- a. If fuel pump has not been primed, refer to paragraph 2-8d and prime pump.
 - b. If fuel pump has been primed, proceed to next step.
- Step 5. Inspect fuel filter cover for loose hardware.
- a. If fuel filter cover is loose, tighten connections.
 - b. If fuel filter cover is not loose, report problem to your supervisor.

Table 3-2. Troubleshooting (Continued)

MALFUNCTION	TEST OR INSPECTION	CORRECTIVE ACTION
5. FUEL PRESSURE TOO LOW OR FUEL PRESSURE PULSATES (WATER HEATER/DRYER). (Cont).		
	Step 6.	Check for clogged fuel filter.
	a.	If fuel filter is clogged, refer to paragraph 3-7 and perform maintenance on fuel filter.
	b.	If problem persists, notify your supervisor.
6. FUEL PUMP FAILS TO DELIVER FUEL TO BURNER (WATER HEATER/DRYER).		
WARNING		
Fuel is very flammable and can explode easily. To avoid serious injury or death, keep fuel away from open fire and keep fire extinguisher within easy reach when working with fuel. Do not work on fuel system when burner is hot. Fuel can be ignited by hot burner. Shut off engine and do not smoke while refueling.		
	Step 1.	Check for proper rotation of fuel pump.
	a.	If fuel pump rotates in wrong direction, notify your supervisor.
	b.	If fuel pump rotates in proper direction, proceed to next step.
	Step 2.	Check fuel supply in fuel drum.
	a.	If fuel supply is low, fill fuel drum.
	b.	If fuel supply is adequate, proceed to next step.
	Step 3.	Inspect fuel hose for air leaks.
	a.	If leaks are present, tighten fuel hose connections.
	b.	If no leaks are present, proceed to next step.
	Step 4.	Check supply and return hose assemblies to see if they are reversed.
	a.	If supply and return hoses are reversed, disconnect and reconnect them in proper positions.
	b.	If supply and return hoses are not reversed, proceed to next step.
	Step 5.	Check fuel pump to verify that it has been primed.
	a.	If fuel pump has not been primed, refer to paragraph 2-8d and prime pump.
	b.	If fuel pump has been primed, proceed to next step.

Table 3-2. Troubleshooting (Continued)

MALFUNCTION	TEST OR INSPECTION	CORRECTIVE ACTION
--------------------	---------------------------	--------------------------

6. FUEL PUMP FAILS TO DELIVER FUEL TO BURNER (WATER HEATER/DRYER). (Cont)

- Step 6. Inspect fuel filter cover for loose hardware.
 - a. If fuel filter cover is loose, secure hardware.
 - b. If fuel filter cover is not loose, proceed to next step.
- Step 7. Check for clogged fuel filter.
 - a. If fuel filter is clogged, refer to paragraph 3-7 and perform maintenance on fuel filter.
 - b. If problem persists, notify your supervisor.

7. BLACK SMOKE COMES OUT OF BURNER EXHAUST DUCT (WATER HEATER/DRYER).

Check to see if fuel-to-air ratio adjustment is correct.

- a. If fuel-to-air ratio adjustment is incorrect, refer to paragraph 3-7 and adjust shutter for proper volume of air intake.
- b. If fuel-to-air ratio adjustment is correct, notify your supervisor.

8. EXTRACTOR FAILS TO START.

- Step 1. Check emergency stop button and see if it is pushed in.
 - a. If emergency stop button is pushed in, reset by pulling emergency stop button out.
 - b. If emergency stop is reset, proceed to next step.
- Step 2. Check lid on extractor and make sure it is closed and locked in position.
 - a. If lid is open, close and lock in correct position.
 - b. If lid is closed and locked in position, proceed to next step.
- Step 3. Check to see if power is available to extractor. Check to see if circuit breaker on power distribution panel is off.
 - a. If circuit breaker is off, reset circuit breaker.
 - b. If power is not available, notify your supervisor.

Table 3-2. Troubleshooting (Continued)

MALFUNCTION	TEST OR INSPECTION	CORRECTIVE ACTION
9. EXTRACTOR BASKET FAILS TO TURN.		
Check lid on extractor and make sure it is closed. Inspect indicator light on control box. Indicator should light if lid is closed.		
<ul style="list-style-type: none"> a. If lid is not closed, close lid and press start button. b. If lid is closed and extractor basket will not turn after pressing start button, report problem to unit maintenance. 		
10. EXTRACTOR FAILS TO DRAIN.		
Remove and inspect drain hose for kinks and/or clogged condition.		
<ul style="list-style-type: none"> a. If hose is clogged, remove hose and remove clog. b. If drain is not kinked or clogged, notify your supervisor. 		
11. WASHER FAILS TO FILL WITH WATER.		
Step 1.	Check water pump for proper operation. Refer to malfunction 1.	
<ul style="list-style-type: none"> a. If water pump is not operational, notify your supervisor. b. If water pump is operational, proceed to next step. 		
Step 2.	Inspect input line for kinks and/or loose connections.	
<ul style="list-style-type: none"> a. Straighten lines and secure connections. b. If washer still fails to fill, proceed to next step. 		
Step 3.	Check to see if hot and cold water valves operate. Valves should open and close when switches on the controller are activated.	
<ul style="list-style-type: none"> a. If valves do not operate properly, notify your supervisor. b. If washer still fails to fill, proceed to next step. 		
Step 4.	Check air pressure gage on air tank for an indication of at least 70 psi (483 kPa).	
<ul style="list-style-type: none"> a. If pressure is 70 psi (483 kPa) or above, proceed to next step. b. If pressure is below 70 psi (483 kPa) check circuit breaker on power distribution box for the air compressor. 		

Table 3-2. Troubleshooting (Continued)

MALFUNCTION	TEST OR INSPECTION	CORRECTIVE ACTION
11. WASHER FAILS TO FILL WITH WATER. (Cont)		
Step 5.	Check water float level.	Check float rod to see if it is sticking. If float rod is sticking and cannot be freed or is damaged, notify your supervisor.
12. WASHER FILLS WITH WRONG AMOUNT OF WATER.		
Step 1.	Inspect controller switches to determine whether switches are in the correct positions.	<ul style="list-style-type: none"> a. Set switches on controller to compensate. b. If problem persists, proceed to next step 2.
Step 2.	Check to see if float level (2, FIG. 2-1) is sticking.	<ul style="list-style-type: none"> a. Free the float operation. b. If water level problems persist, report problem to unit maintenance.
Step 3.	Check to see if hot and cold water valves operate. Valves should open and close when switches on controller are activated.	<ul style="list-style-type: none"> a. If valves do not operate properly, notify your supervisor. b. If valves operate properly, proceed to next step.
Step 4.	Check air pressure gage on air tank for an indication of at least .70 psi (483 kPa).	<ul style="list-style-type: none"> a. If pressure is below 70 psi (483 kPa), check circuit breaker on power distribution box for the air compressor. b. If pressure is 70 psi (483 kPa), notify your supervisor.
13. WASHER FILLS WITH WRONG TEMPERATURE OF WATER.		
Step 1.	Check for proper switch settings on controller.	<ul style="list-style-type: none"> a. Set switches to proper setting. b. If temperature problem persists, proceed to next step.

Table 3-2. Troubleshooting (Continued)

MALFUNCTION	TEST OR INSPECTION	CORRECTIVE ACTION
13. WASHER FILLS WITH WRONG TEMPERATURE OF WATER. (Cont)		
Step 2.	Check for proper thermostat setting on water heater.	
a.	If setting is incorrect, refer to malfunction 2, step 2.	
b.	If correct temperature cannot be obtained, notify your supervisor.	
14. WASHER FAILS TO TUMBLE.		
Step 1.	Check positions of switches on controller.	
a.	Position the switches to effect proper tumbling action.	
b.	If washer still fails to tumble, proceed to next step.	
Step 2.	Check to ensure washer door is closed.	
a.	If the door is not closed, close the door and secure.	
b.	If door is closed and secure, proceed to next step.	
Step 3.	Check to see if controller reset button (22, FIG. 2-1) is tripped.	
a.	If controller reset button is tripped, push reset button.	
b.	If reset button is not tripped, proceed to next step.	
WARNING		
Remove rings, bracelets, wristwatches, and neck chains before working around or on the laundry unit. Jewelry can catch on equipment and cause injury, or may short across an electrical circuit and cause severe burns or electrical shock. Ensure circuit breakers are in the OFF position.		
Step 4.	Check drive mechanism for missing or damaged belt. Report missing or damaged belts to your supervisor.	

Table 3-2. Troubleshooting (Continued)

MALFUNCTION	TEST OR INSPECTION	CORRECTIVE ACTION
-------------	--------------------	-------------------

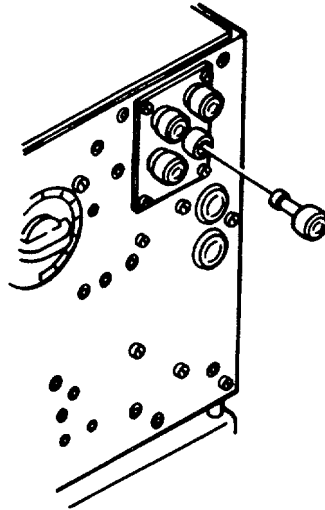
14. WASHER FAILS TO TUMBLE.

Step 5. Check for blown fuses on side of controller. Replace suspect fuses with a known good fuse.

If problem still persists, notify your supervisor.

15. WASHER FAILS TO DRAIN.

Step 1. Check controller switches for proper position.

- a. Position switches as needed.
- b. If switches are in proper position, proceed to next step.

Step 2. Check drain hose for kinks and/or clogged condition.

- a. If hose is kinked or clogged, disconnect hose and remove foreign material. Connect hose and straighten kinks.
- b. If drain hose is not kinked or clogged, proceed to next step.

Step 3. Check drain hose air valves for loose couplings and damage. If air hose valves are loose or damaged, notify your supervisor.

Section III. MAINTENANCE PROCEDURES

Para	Title	Page
3-6	Introduction	3-13
3-7	Maintenance Procedures.....	3-13

3-6. INTRODUCTION. This section provides instructions for inspection, service, and adjustment of assemblies and subassemblies of the laundry unit. Each maintenance procedure contains step-by-step instructions for the task to be performed.

3-7. MAINTENANCE PROCEDURES.

a. Generator Maintenance. Refer to TM 5-6115-585-12 for performing maintenance on the 10-kW generator.

b. Trailer Assembly Maintenance. Refer to TM 9-2330-376-14&P for performing maintenance on the trailer assembly.

c. Water Heater Fuel Filter Maintenance. These instructions tell how to inspect and service the fuel filter assembly on the laundry water heater.

- (1) Inspect fuel filter assembly for damage and leaks.

3-7. MAINTENANCE PROCEDURES. (CONT)

- (2) Service fuel filter by turning handle (1) a few times to clean the permanent element. Remove drain plug (2) and allow moisture and sediment to drain from bowl. Install drain plug.

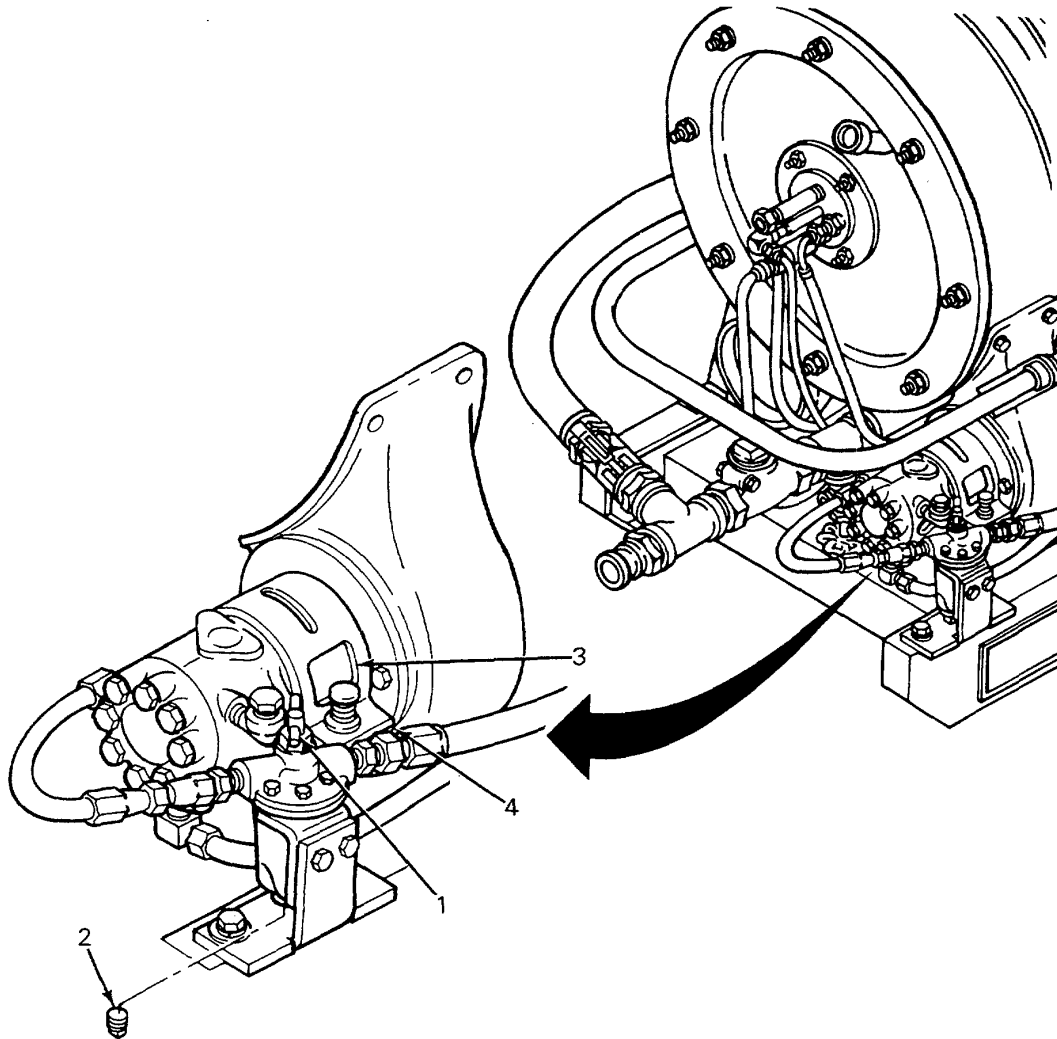

d. Water Heater Air Shutter Assembly Maintenance These instructions tell how to inspect and adjust the air shutter assembly on the water heater.

- (1) Inspect air shutter for binding of moving parts and for damage.
- (2) Adjust air shutter (3) by grasping slider band (4) and rotating band up or down to increase or decrease air opening. Adjust air opening during operation to obtain a light-colored exhaust and rumble-free operation.

3-7. MAINTENANCE PROCEDURES. (CONT)

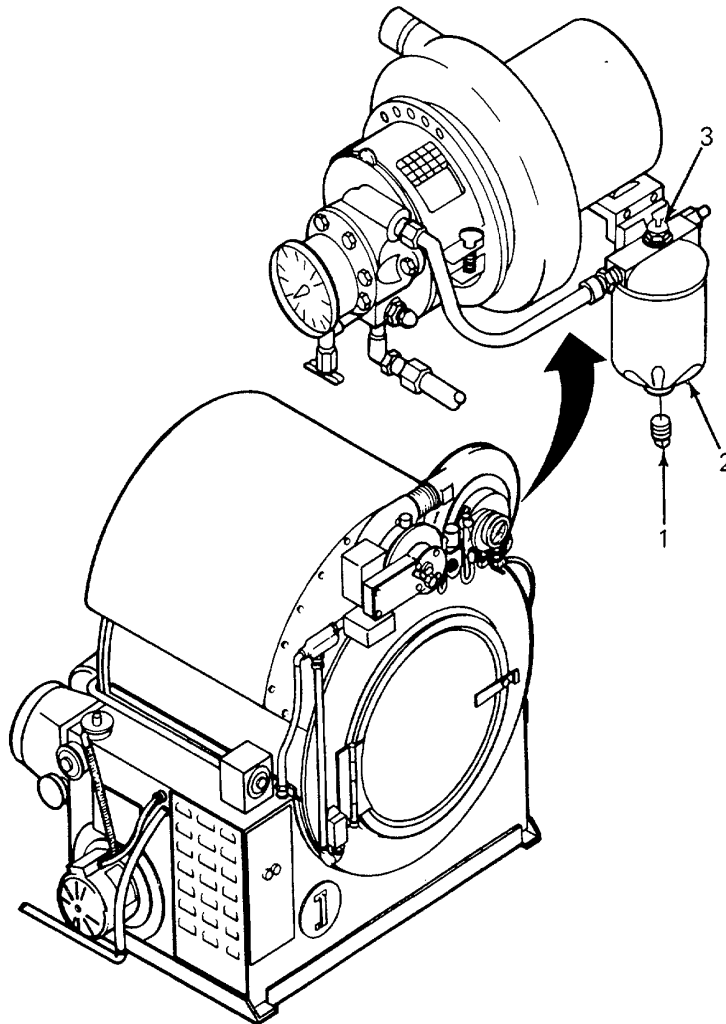

e. Drying Tumbler Fuel Filter Maintenance. These instructions tell how to inspect and service the fuel filter assembly on the laundry drying tumbler.

(1) Inspect fuel filter assembly for damage and leaks.

(2) Service fuel filter by removing drain plug (1) on bottom of bowl (2). Open air vent screw (3) on top of filter assembly. Drain enough fuel from bowl to remove contaminants. Tighten air vent screw and close drain valve.

3-7. MAINTENANCE PROCEDURES. (CONT)

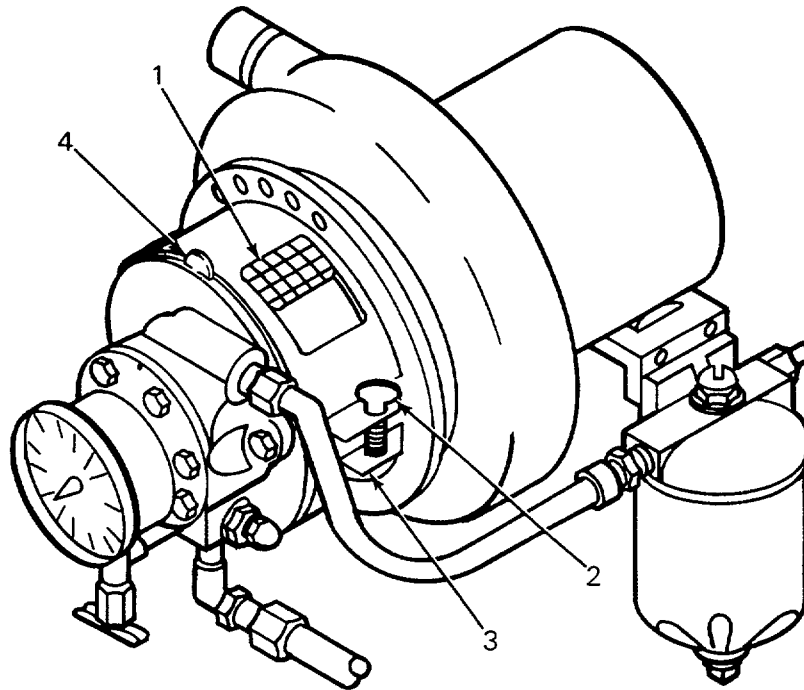

f. Drying Tumbler Air Shutter Assembly Maintenance. These instructions tell how to inspect and adjust the air shutter assembly on the drying tumbler.

- (1) Inspect burner air intake (1) for damage and for binding of moving parts.
- (2) Adjust burner air intake (1) by loosening wingbolt (2) and sliding band. (3) up or down to increase or decrease air opening. Adjust air shutter. (4) during operation to obtain a light-colored exhaust and rumble-free operation.

A-3. TECHNICAL PUBLICATIONS. (CONT)

TM 10-3510-209-24	Unit, Intermediate Direct Support, and Intermediate General Support Maintenance Manual; Laundry, Trailer-Mounted, Army Model M85
TM 5-6115-585-12	Operator and Organizational Maintenance Manual for Generator Set, Diesel, Engine Driven, 10 kW, 60 Hz
TM 9-2330-376-14&P	Operator's, Organizational, Direct Support, and General Support Maintenance Manual for Trailer, Flatbed, General Purpose, 5-Ton, 4-Wheel, M1061 EI
TM 750-244-6	Procedures for Destruction of Tank-Automotive Equipment to Prevent Enemy Use

b. Lubrication Order

LO 10-3510-209-12	Lubrication Order, Laundry Unit, Trailer-Mounted, M85
LO 5-6115-585-12	Lubrication Order, Generator Set, Diesel Engine Driven, Tactical Skid Mounted, 10 kW
LO 9-2330-376-14&P	Lubrication Order, Trailer, Flatbed, General Purpose, 5-Ton, 4-Wheel, XM1061 EI

APPENDIX B

COMPONENTS OF END ITEM AND BASIC ISSUE ITEMS LISTS

Section I. INTRODUCTION

B-1. SCOPE. This appendix lists components of end item and basic issue items for the laundry unit to help you inventory items required for safe and efficient operation.

B-2. GENERAL. The Components of End Item and Basic Issue Items lists are divided into the following sections:

a. Section II. Components of End Item. This listing is for informational purposes only, and is not authority to requisition replacements. These items are part of the end item, but are removed and separately packaged for transportation or shipment. As part of the end item, these items must be with the end item whenever it is issued or transferred between property accounts. Illustrations are furnished to assist you in identifying the items.

b. Section III. Basic Issue Items. These are the minimum essential items required to place the laundry unit in operation, to operate it, and to perform emergency repairs. Although shipped separately packaged, BII must be with the laundry unit during operation and whenever it is transferred between property accounts. The illustrations will assist you with hard-to-identify items. This manual is your authority to request/requisition replacement BII, based on TOE/MTOE authorization of the end item.

B-3. EXPLANATION OF COLUMNS. The following provides an explanation of columns found in the tabular listings:

a. Column (1)-Illustration Number (Illus Number). This column indicates the number of the illustration in which the item is shown.

b. Column (2)-National Stock Number. Indicates the National Stock Number assigned to the item and will be used for requisitioning purposes.

c. Column (3)-Description. Indicates the Federal item name and, if required, a minimum description to identify and locate the item. The last line for each item indicates the CAGE (in parentheses) followed by the part number.

d. Column (4)-Unit of Measure. (U/M). Indicates the measure used in performing the actual operational/maintenance function. This measure is expressed by a two-character alphabetical abbreviation (e.g., ea, in., pr).

e. Column (5)-Quantity Required (Qty Reqd). Indicates the quantity of the item authorized to be used with/on the equipment.

Section II. COMPONENTS OF END ITEM

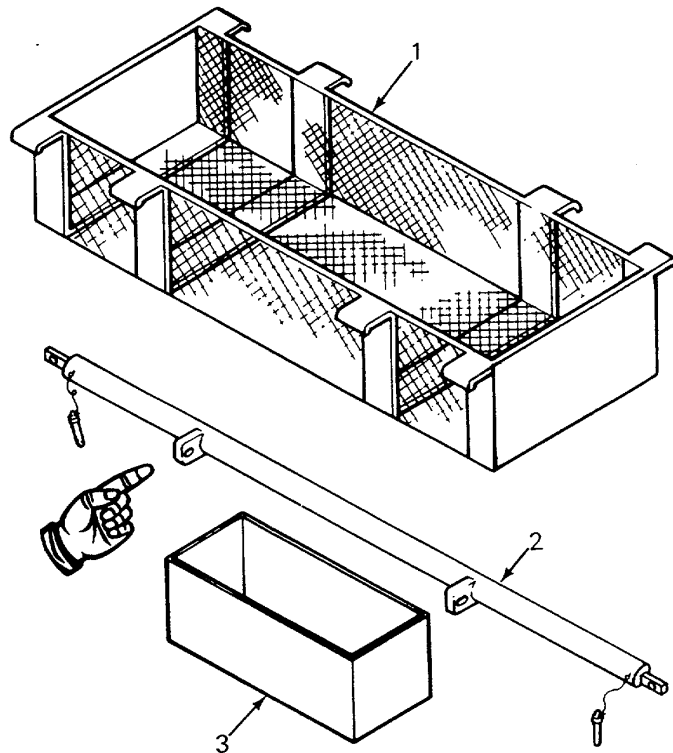

(1) ILLUS NO.	(2) NATIONAL STOCK NUMBER	(3) DESCRIPTION CAGE AND PART NUMBER	(4) U/M	(5) QTY REQD
1		BASKET ASSY, HOSE (81337) 6-1-9955	EA	2
2		BEAM ASSY, LEFT (81337) 6-2-2418	EA	1
3	3510-01-248-5296	BIN, DRY CLOTHES (81337) 6-1-9906	EA	1

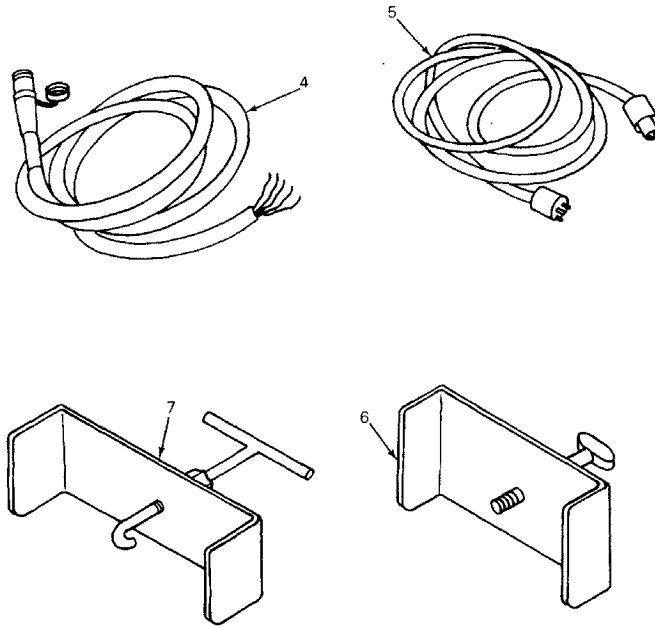

(1) ILLUS NO.	(2) NATIONAL STOCK NUMBER	(3) DESCRIPTION CAGE AND PART NUMBER	(4) U/M	(5) QTY REQD
4	6150-01-275-7930	CABLE, POWER, GENERATOR TO CONTROL PANEL (81337) 6-1-9924	EA	1
5		CABLE, POWER, WATER HEATER TO WATER PUMP (81337) 6-1-9926	EA	1
6	3510-01-279-3980	CLAMP, HOLDING, WORK PLATFORM (81337) 6-1-9433	EA	1
7	3510-01-247-4797	CLAMP, HOOK (81337) 6-1-9430	EA	1

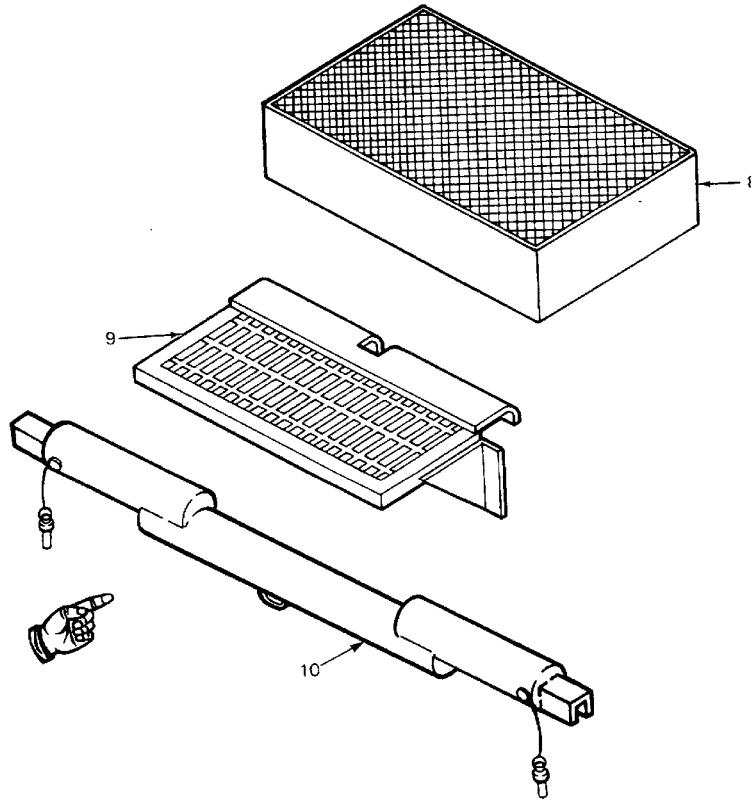

(1) ILLUS NO.	(2) NATIONAL STOCK NUMBER	(3) DESCRIPTION CAGE AND PART NUMBER	(4) U/M	(5) QTY REQD
8	3510-01-245-6934	PANEL, SOUND DEADENING SIDE PANEL SMALL (81337) 1-6-0114	EA	2
	5640-01-285-4288	SIDE PANEL LARGE (81337) 6-2-2400	EA	1
	3510-01-246-9256	TOP PANEL (81337) 1-6-0118	EA	3
9	3510-01-242-7258	STEP ASSY, PLATFORM (81337) 6-1-9949	EA	2
10	3510-01-246-9258	STRUT ASSY, TARP (81337) 6-1-9416	EA	2

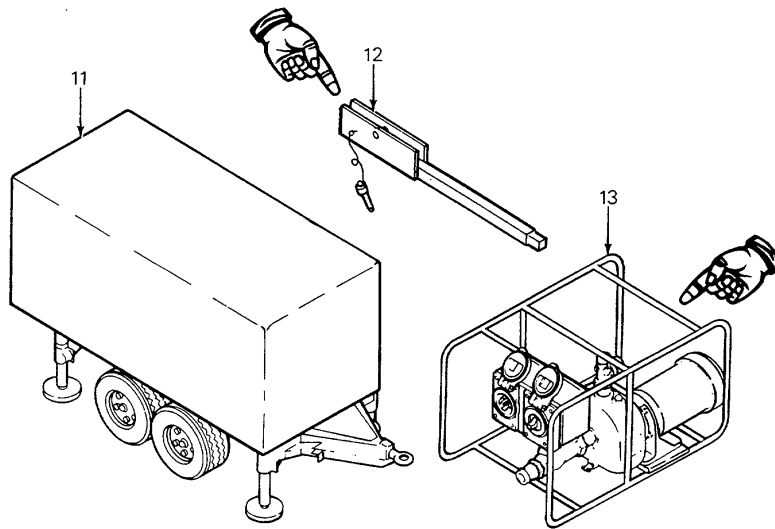

(1) ILLUS NO.	(2) NATIONAL STOCK NUMBER	(3) DESCRIPTION CAGE AND PART NUMBER	(4) U/M	(5) QTY REQD
11	3510-01-253-4303	TARPAULIN (81337) 6-1-9962	EA	1
12	3510-01-250-3645	WORKSTAND STORAGE SUPPORTS (81337) 6-1-9859	EA	2
13	4510-01-245-6936	WATER PUMP ASSY (81337) 6-1-9932	EA	1

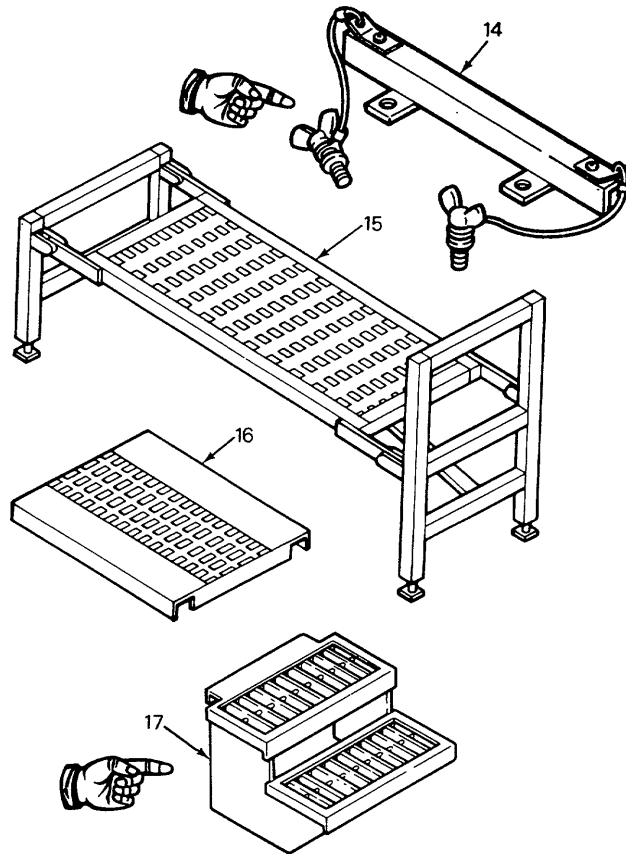

(1) ILLUS NO.	(2) NATIONAL STOCK NUMBER	(3) DESCRIPTION CAGE AND PART NUMBER	(4) U/M	(5) QTY REQD
14		WATER PUMP HOLDDOWN ASSY (81337) 6-1-9443	EA	2
15		WORK PLATFORM ASSY, WASHER (HIGH) (81337) 6-1-8356 WORK PLATFORM ASSY, DRYER (LOW) (81337) 6-2-2411	EA	1
16		WORK PLATFORM ASSY, SHORT (81337) 6-1-9855	EA	1
17		TWO STEP ASSY (81337) 6-2-2403	EA	1

Section III. BASIC ISSUE ITEMS

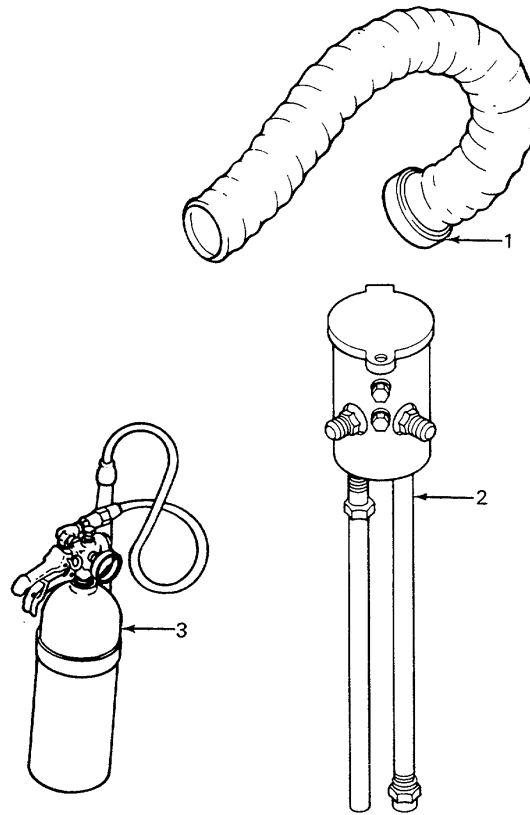

(1) ILLUS NO.	(2) NATIONAL STOCK NUMBER	(3) DESCRIPTION CAGE AND PART NUMBER	(4) U/M	(5) QTY REQD
1	4720-00-930-5974	DUCT, DRYER TUMBLER LINT (81349) MIL-H-7365, SIZE A	EA	1
2	4510-01-214-9139	DRUM FILL ADAPTER ASSY (81337) 6-1-8285	EA	2
3	4210-00-899-2491	EXTINGUISHER, FIRE (81348) A-A-393	EA	1
4		DELETED		

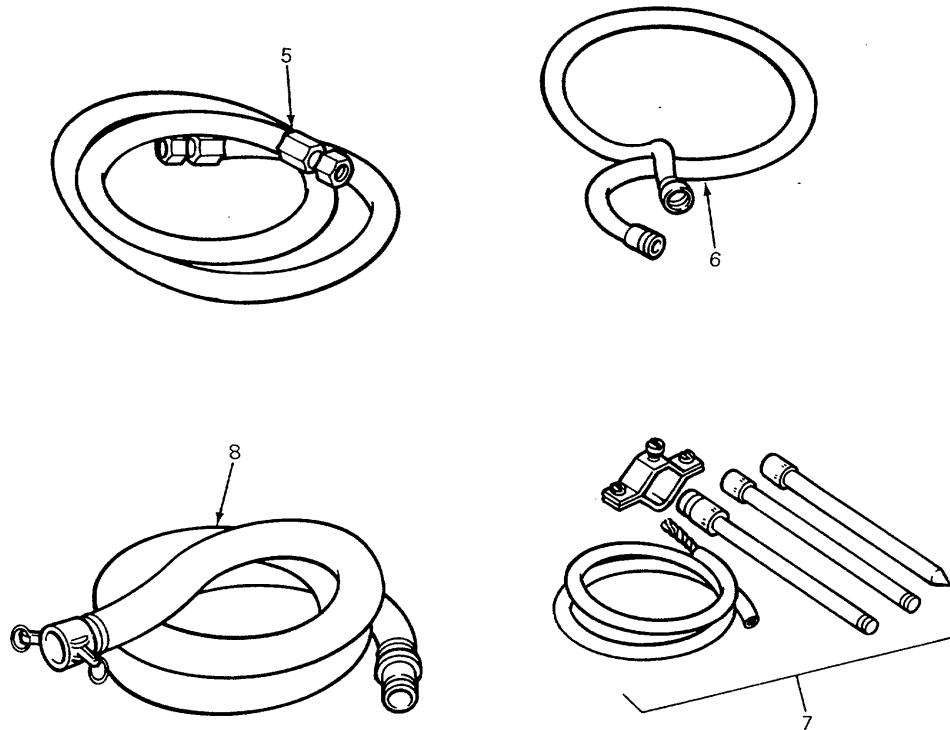

(1) ILLUS NO.	(2) NATIONAL STOCK NUMBER	(3) DESCRIPTION CAGE AND PART NUMBER	(4) U/M	(5) QTY REQD
5	4720-00-064-0832	HOSE, FUEL RETURN (81337) 6-1-9836-65	EA	4
6	4720-00-202-6721	HOSE, GARDEN, 6-FOOT (81348) L-H-520-6	EA	1
7	5975-00-878-3791	GROUND ROD ASSY, SECTIONAL, W/ATTACHMENTS MIL-R-11461 (81349)	EA	1
8	4720-01-B76-7729	HOSE ASSY, DRAIN, EXTRACTOR-TO- DRAIN FIELD (81337) 6-1-9946-3	EA	1

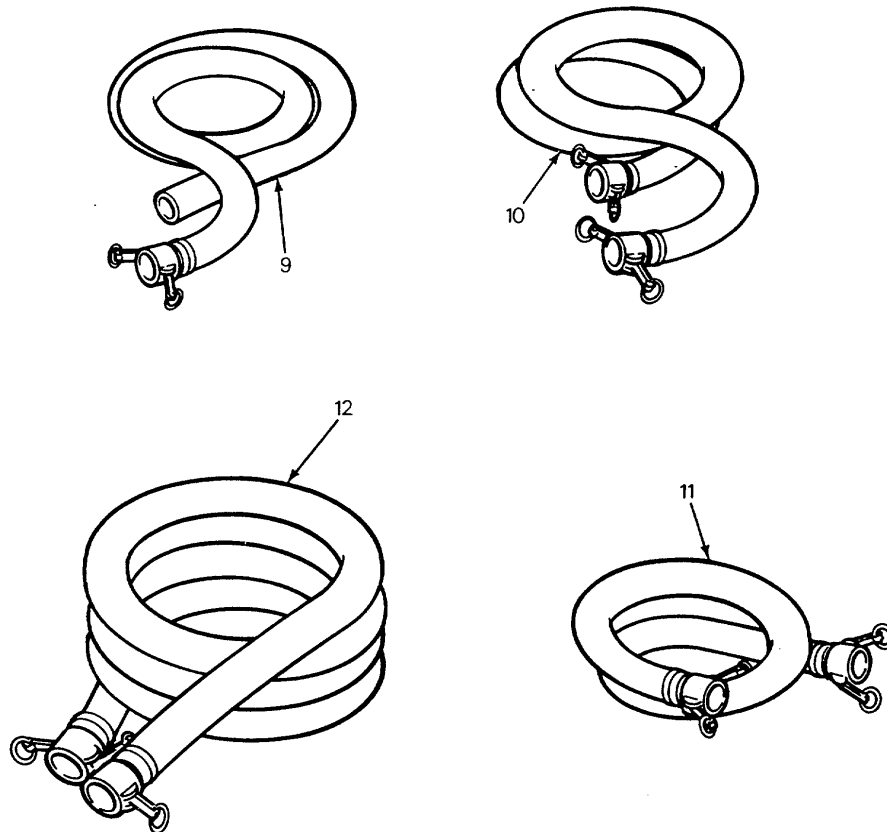

(1) ILLUS NO.	(2) NATIONAL STOCK NUMBER	(3) DESCRIPTION CAGE AND PART NUMBER	(4) U/M	(5) QTY REQD
9	4720-01-B76-7728	HOSE ASSY, PRE-EXTRACT DRAIN (81337) 6-1-9946-2	EA	1
10	4720-00-707-1106	HOSE ASSY, SOURCE-TO-WATER-PUMP AND WATER-PUMP-TO-HEATER (81337) 6-1-746-7	EA	2
11	4720-01-B76-8033	HOSE ASSY, WATER-HEATER-TO-WASHER (81337) 6-1-9946-1	EA	1
12	4720-01-B76-7730	HOSE ASSY, MAIN DRAIN (81337) 6-1-9995-4	EA	1

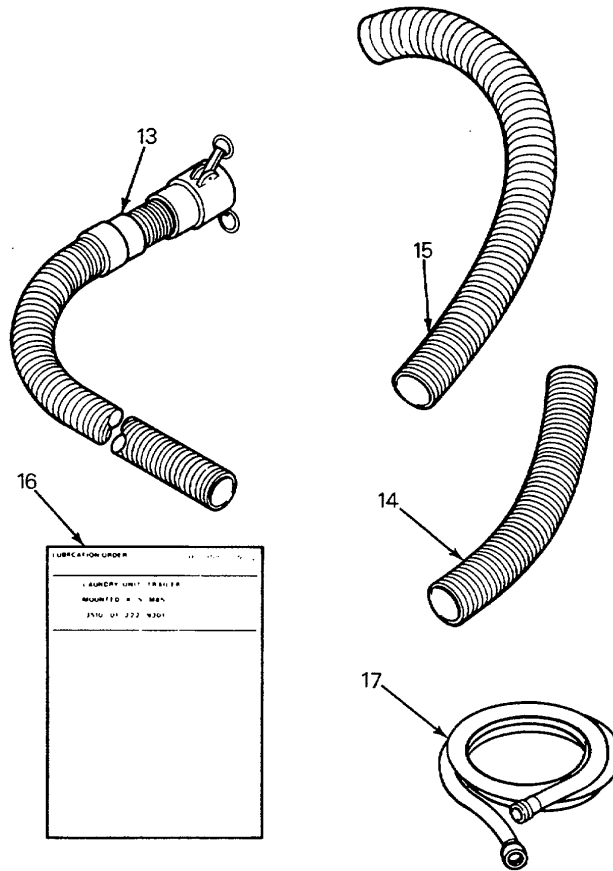

(1) ILLUS NO.	(2) NATIONAL STOCK NUMBER	(3) DESCRIPTION CAGE AND PART NUMBER	(4) U/M	(5) QTY REQD
13	4720-00-903-4148	DUCT, GENERATOR EXHAUST (81337) 6-2-2419	EA	2
14	4520-00-950-6359	DUCT, WATER HEATER EXHAUST (81337) 6-2-2427	EA	2
15	4720-01-261-6815	DUCT, DRYER EXHAUST (81337) 6-2-2303	EA	1
16		LUBRICATION ORDER LO 10-3510-209-12	EA	1
17	4720-00-729-5334	HOSE, GARDEN, 50-FOOT (81348) L-H-520	EA	1

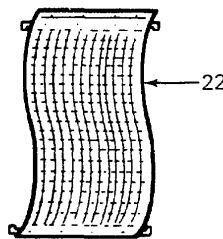
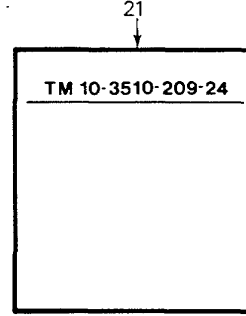
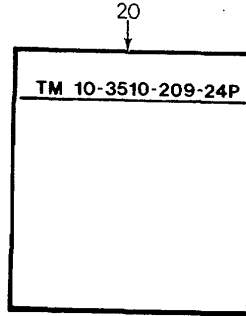
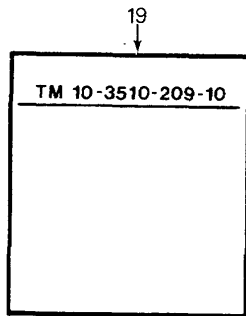
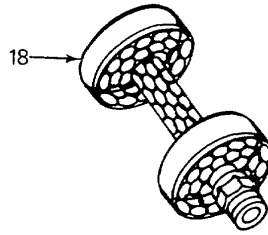

(1) ILLUS NO.	(2) NATIONAL STOCK NUMBER	(3) DESCRIPTION CAGE AND PART NUMBER	(4) U/M	(5) QTY REQD
18	4730-01-249-1969	STRAINER, SUCTION (81337) 6-1-8359	EA	1
19		OPERATOR'S MANUAL TM 10-3510-209-10	EA	1
20		MAINTENANCE REPAIR PARTS AND SPECIAL TOOLS LISTS MANUAL TM 10-3510-209-24P	EA	1
21		MAINTENANCE MANUAL TM 10-3510-209-24	EA	1
22	3510-01-283-4610	PRE-CUT WASHER CONTROL CHARTS	SE	1

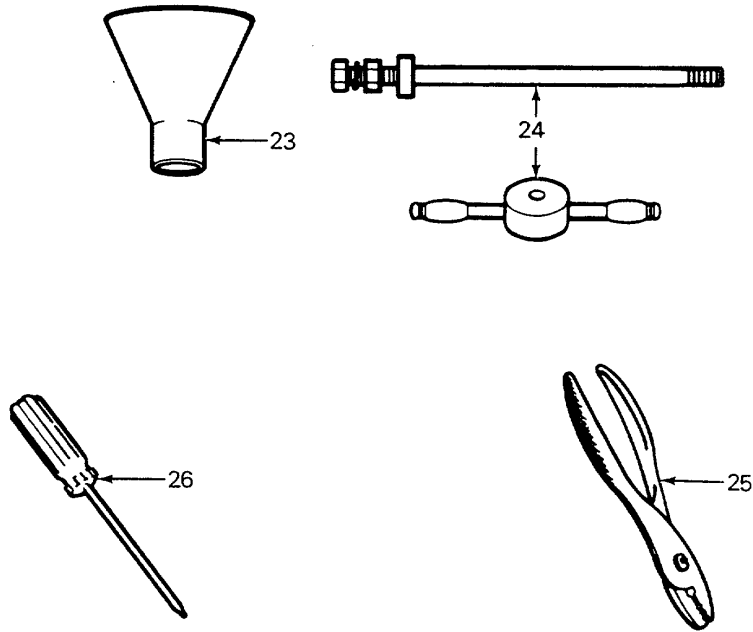

(1) ILLUS NO.	(2) NATIONAL STOCK NUMBER	(3) DESCRIPTION CAGE AND PART NUMBER	(4) U/M	(5) QTY REQD
23	6640-00-063-7879	FUNNEL, COMMON LAB, PLASTIC, POLYETHYLENE 802PE (95352)	EA	1
24	5120-01-013-1676	SLIDE HAMMER, GROUND ROD EMPLACEMENT (45225) P74-144	EA	1
25	5120-01-278-0352	PLIERS, SLIP JOINT: 10-IN., ADJUSTABLE (80212) P489	EA	1
26	5120-01-234-8912	SCREWDRIVER, CROSS TIP: 6-IN. (C7127) SSDP63	EA	1

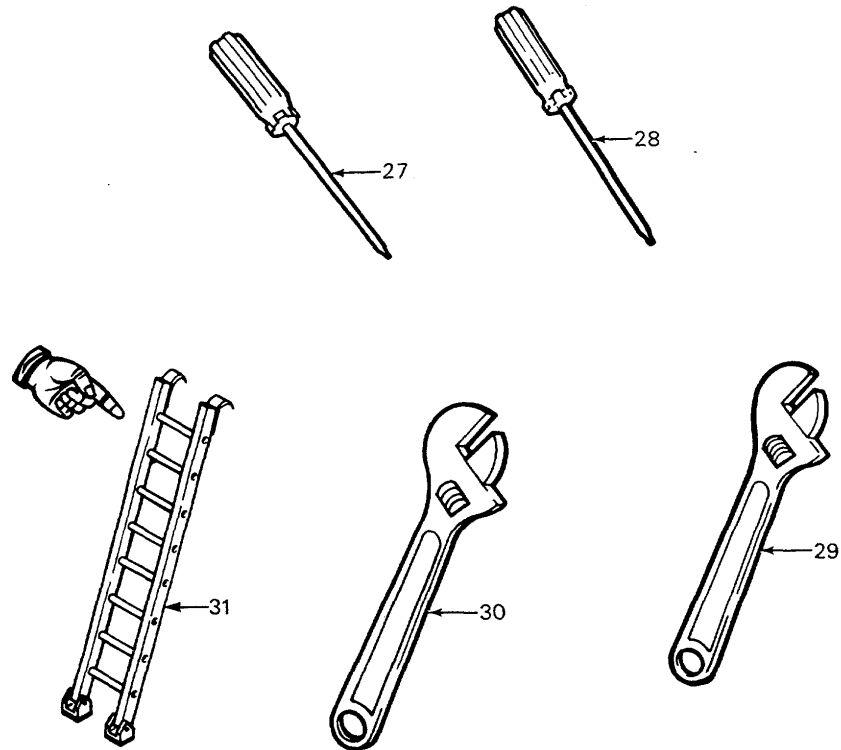

(1) ILLUS NO.	(2) NATIONAL STOCK NUMBER	(3) DESCRIPTION CAGE AND PART NUMBER	(4) U/M	(5) QTY REQD
27	5120-00-237-6985	SCREWDRIVER, FLAT TIP: 8-IN.	EA	1
28 10-IN.	5120-00-227-7334	SCREWDRIVER, FLAT TIP:	EA	1
29	5120-00-240-5328	WRENCH, OPEN END, ADJUSTABLE: 8-IN.	EA	1
30	5120-01-264-3796	WRENCH, OPEN END, ADJUSTABLE: 12-IN.	EA	1
31		LADDER ASSY (81337) 6-2-2426	EA	1

APPENDIX C

EXPENDABLE/DURABLE SUPPLIES AND MATERIALS LIST

Section I. INTRODUCTION

C-1. SCOPE. This appendix lists expendable supplies and materials you will need to operate and maintain the laundry unit. This listing is for informational purposes only and is not authority to requisition the listed items. These items are authorized to you by CTA 50-970, Expendable/Durable Items (Except Medical, Class V, Repair Parts, and Heraldic Items), or CTA 8-100, Army Medical Department Expendable/Durable Items.

C-2. EXPLANATION OF COLUMNS.

- a. Column(1) - Item Number. This number is assigned to the entry in the listing and is referenced in the narrative instructions to identify the material, e.g., Use cleaning compound (item 5, app D).
- b. Column(2) - Level. This column identifies the lowest level of maintenance that requires the listed item.

C - Operator/Crew
0 - Unit
F - Intermediate Direct Support
H - Intermediate General Support
- c. Column(3) - National Stock Number. This is the National stock number assigned to the item; use it to request or requisition the item.
- d. Column(4) - Description. Indicates the Federal item name and, if required, a description to identify the item. The last line for each item indicates the Government and Commercial Entity (CAGE) in parentheses, followed by the part number.
- e. Column(5) - Unit of Measure (U/M). Indicates the measure used in performing the actual maintenance function. This measure is expressed by a two-character alphabetical abbreviation (e.g., ea, in., pr). If the unit of measure differs from the unit of issue, requisition the lowest unit of issue that will satisfy your requirements.

Section II. EXPENDABLE / DURABLE SUPPLIES AND MATERIAL LIST

(1) ITEM NO.	(2) LEVEL	(3) NATIONAL STOCK NUMBER	(4) DESCRIPTION	(5) U/M
1	C	7930-00-965-9830	Agent, Antistatic	EA
2	C		Agent, Chelate	EA
3	C	6850-01-015-7939	Agent, Prespotting	EA
4	C	6850-00-297-6653	Bleach, Super Tropical	EA
5	C	8030-00-264-3875	Compound, Water Repellant, Textile Finish, Type I, Aqueous	GL
6	C	6810-00-141-2942	Crystals, Citric Acid	EA
7	C	7930-00-929-1220	Detergent, Type I	EA
8	C	7930-00-929-1221	Detergent, Type II, P-D-245	EA
9	C	7930-00-985-9611	Detergent, Nonionic Type II, Sour, Laundry	EA
10	C	9140-00-286-5284	Fuel, Diesel F-800 (DF-A, DF-1, DF-2)	GL
11	C	9130-01-207-7039	Fuel, MOGAS MIL-G-3056 (All Grades)	GL
12	C	9150-00-985-7246	Grease, Soft MIL-G-23827	EA
13	C	9150-00-186-6668	Oil, Lubricating, Engine, OE30 5-gallon pail	GL
14	C	9150-00-265-9428	Oil, Lubricating, Engine, OE10, 5-gallon pail (81349) MIL-L-2104	GL
15	C		Permanon 40 EC	EA
16	C		Orthosilicate, Sodium	EA
17	C	7930-00-924-5366	Softener, Fabric, Liquid	GL
18	C	5920-01-171-4902	Fuse, 1.5-Amp	EA
19	C	5920-00-660-5963	Fuse, 10-Amp	EA

APPENDIX D

ADDITIONAL AUTHORIZATION LIST

Section I. INTRODUCTION

D-1. SCOPE. This appendix lists additional items that are authorized for the support of the laundry unit.

D-2. GENERAL. The list identifies items that do not have to accompany the laundry unit and that do not have to be turned in with it. These items are all authorized for use by CTA, MTOE, TDA, or JTA.

D-3. EXPLANATION OF LISTINGS. National stock numbers, descriptions, and quantities are provided to help you identify and request the additional items required to support this equipment. The items are listed in alphabetical sequence by item name under the type document (i.e., CTA, MTOE, TDA, or JTA) which authorizes the item(s) to you.

Section II. ADDITIONAL AUTHORIZATION LIST

(1) NATIONAL STOCK NUMBER	(2) DESCRIPTION		(3)	(4)
	FSCM & PART NUMBER	USABLE ON CODE	U/M	QTY AUTH
4230-01-133-4124	Decontaminating Apparatus (81349) MIL-D-12468		EA	1
	Fuel Drum: 55-gal (81348) PPP-D-1152B		EA	2

Change 1 D-2

INDEX

Subject	Page
A	
Abbreviations.....	1-2
Additional Authorization List (AAL).....	D-1
Assembly, site selection; setup and.....	2-30
B	
Basic issue items.....	B-7
C	
Checks and services, preventive maintenance.....	2-14
Components of end item and basic issue items.....	B-1
Components, major, location and description.....	1-4
Contents, table of.....	i
Control finger functions.....	2-58
Controls and indicators, description and use of.....	2-1
Cross-reference list, nomenclature.....	1-2
D	
Data, equipment.....	1-7
Data plate.....	2-76
Decals and instruction plates, operating instructions on.....	2-74
Description of major components, location and.....	1-4
Dust or sand, operation in.....	2-79
E	
Emergency procedures.....	2-79
Equipment description:	
Equipment purpose, capabilities, and features.....	1-3
Location and description of major components.....	1-4
Equipment improvement recommendations' (EIR), reporting.....	1-1
Equipment:	
Capabilities.....	1-3
Data.....	1-7
Feature.....	1-3
Purpose.....	1-3
Expendable supplies and materials list.....	C-2
Extreme cold, operation in.....	2-78
F	
Features of equipment.....	1-3
Finger functions, control.....	2-58
Forms and records, maintenance.....	1-1

Subject	Page
G	
General information:	
Abbreviations.....	1-2
Equipment data.....	1-7
Hand receipt (HR) manuals.....	1-1
Maintenance forms and records.....	1-1
Metric system.....	1-1
Nomenclature cross-reference list.....	1-2
Reference information.....	1-2
Scope	1-1
Warranty information	1-1
General maintenance procedures.....	2-16
Generator maintenance (Refer to TM 5-6115-585-12)	
Glossary	1-2
H	
Hand receipt (HR) manuals.....	1-1
How to use this manual.....	iii
I	
Indicators, description and use of operator's controls.....	2-1
Indicators, location and use of controls and.....	2-3
Information, reference	1-2
Information, warranty.....	1-1
Index, symptom.....	3-2
Instruction plates, operating instructions on decals and.....	2-74
L	
List, nomenclature cross-reference.....	1-2
List of weights.....	2-63
Location and description of major components.....	1-4
Location and use of controls and indicators.....	2-1
Lubrication instructions.....	3-1
Lubrication references.....	3-1
M	
Maintenance:	
General maintenance procedures.....	2-14
Preventive checks and service.....	2-14
Maintenance forms and records.....	1-1
Maintenance instructions:	
Generator (Refer to TM 5-6115-585-12)	
Lubrication instructions.....	3-1
Maintenance procedures.....	3-13
Trailer assembly (Refer to TM 9-2330-376-14&P)	
Troubleshooting procedures.....	3-1

Subject	Page
M (cont)	
Major components, location and description.....	1-4
Manuals, hand receipt (HR).....	1-1
Materials, expendable.....	C-2
Metric system	1-1
Movement, preparation for.....	2-69
N	
Nomenclature cross-reference list.....	1-2
O	
Operating instructions:	
Description and use of controls and indicators.....	2-1
On decals and instruction plate.....	2-74
Operation of generator set (Refer to TM 5-6115-585-12)	
Operation under unusual conditions.....	2-78
Operation under usual conditions.....	2-30
Preventive maintenance checks and services (PMCS).....	2-14
Operating procedures.....	2-9
Operation under unusual conditions:	
Emergency procedures.....	2-78
Operation in extreme cold.....	2-78
Operation in dust or sand.....	2-79
Operation in saltwater areas.....	2-79
Operation in snow or mud.....	2-79
Operation under usual conditions:	
Introduction.....	2-30
Controls and indicators, description and use of.....	2-1
P	
Preparation for movement.....	2-69
Preparation for use.....	2-47
Preventive maintenance checks and services.....	2-14
Principles of operation.....	1-9
Procedures, emergency.....	2-79
Procedures, operating.....	2-9
Purpose of equipment.....	1-3
R	
Records, maintenance forms and.....	1-1
Reference information.....	1-2
References.....	A-1
References, lubrication.....	3-1
Reporting errors and recommending improvements.....	i
Reporting equipment improvement recommendations.....	1-1

Subject	Page
S	
Saltwater areas, operation.....	2-79
Service:	
Preventive maintenance checks and services (PMCS).....	2-14
Site selection, setup, and assembly.....	2-30
Supplies, expendable.....	C-2
Symptom index	3-2
System, metric	1-1

T

Table of contents.....	i
Technical principles of operation:	
Air compressor.....	1-10
Dryer.....	1-10
Extractor	1-10
Generator and power distribution box.....	1-10
Washer	1-9
Water heater.....	1-10
Water pump.....	1-10
Trailer assembly maintenance (Refer to TM 9-2330-376-14&P)	
Troubleshooting:	
Introduction.....	3-1
Procedures.....	3-1

U

Use of controls and indicators, location and.....	2-1
Use, preparation for.....	2-47

W

Warnings, summary.....	a
Warranty information.....	1-1
Weights, list of.....	2-63

By Order of the Secretary of the Army:

CARL E. VUONO
General, United States Army
Chief of Staff

Official:

R. L. DILWORTH
Brigadier General, United States Army
The Adjutant General

DISTRIBUTION:

To be distributed in accordance with DA Form 12-25A, Operator's Maintenance requirements for Laundry Unit, Single Trailer Mounted, with Canvas Cover, Type M532

☆U.S. GOVERNMENT PRINTING OFFICE: 1993 0 - 342-421 (61731)

RECOMMENDED CHANGES TO EQUIPMENT TECHNICAL PUBLICATIONS



THEN...JOT DOWN THE DOPE ABOUT IT ON THIS FORM. CAREFULLY TEAR IT OUT, FOLD IT AND DROP IT IN THE MAIL.

SOMETHING WRONG WITH PUBLICATION

FROM: (PRINT YOUR UNIT'S COMPLETE ADDRESS)

DATE SENT

PUBLICATION NUMBER	PUBLICATION DATE	PUBLICATION TITLE
--------------------	------------------	-------------------

BE EXACT PIN-POINT WHERE IT IS				IN THIS SPACE, TELL WHAT IS WRONG AND WHAT SHOULD BE DONE ABOUT IT.
PAGE NO.	PARA-GRAPH	FIGURE NO.	TABLE NO.	

TEAR ALONG PERFORATED LINE

PRINTED NAME, GRADE OR TITLE AND TELEPHONE NUMBER	SIGN HERE
---	-----------

DA FORM 1 JUL 79 **2028-2**

PREVIOUS EDITIONS ARE OBSOLETE.

P.S.--IF YOUR OUTFIT WANTS TO KNOW ABOUT YOUR RECOMMENDATION MAKE A CARBON COPY OF THIS AND GIVE IT TO YOUR HEADQUARTERS.

The Metric System and Equivalents

Linear Measure

1 centimeter = 10 millimeters = .39 inch
 1 decimeter = 10 centimeters = 3.94 inches
 1 meter = 10 decimeters = 39.37 inches
 1 dekameter = 10 meters = 32.8 feet
 1 hectometer = 10 dekameters = 328.08 feet
 1 kilometer = 10 hectometers = 3,280.8 feet

Weights

1 centigram = 10 milligrams = .15 grain
 1 decigram = 10 centigrams = 1.54 grains
 1 gram = 10 decigrams = .035 ounce
 1 dekagram = 10 grams = .35 ounce
 1 hectogram = 10 dekagrams = 3.52 ounces
 1 kilogram = 10 hectograms = 2.2 pounds
 1 quintal = 100 kilograms = 220.46 pounds
 1 metric ton = 10 quintals = 1.1 short tons

Liquid Measure

1 centiliter = 10 milliliters = .34 fl. ounce
 1 deciliter = 10 centiliters = 3.38 fl. ounces
 1 liter = 10 deciliters = 33.81 fl. ounces
 1 dekaliter = 10 liters = 2.64 gallons
 1 hectoliter = 10 dekaliters = 26.42 gallons
 1 kiloliter = 10 hectoliters = 264.18 gallons

Square Measure

1 sq. centimeter = 100 sq. millimeters = .155 sq. inch
 1 sq. decimeter = 100 sq. centimeters = 15.5 sq. inches
 1 sq. meter (centare) = 100 sq. decimeters = 10.76 sq. feet
 1 sq. dekameter (are) = 100 sq. meters = 1,076.4 sq. feet
 1 sq. hectometer (hectare) = 100 sq. dekameters = 2.47 acres
 1 sq. kilometer = 100 sq. hectometers = .386 sq. mile

Cubic Measure

1 cu. centimeter = 1000 cu. millimeters = .06 cu. inch
 1 cu. decimeter = 1000 cu. centimeters = 61.02 cu. inches
 1 cu. meter = 1000 cu. decimeters = 35.31 cu. feet

Approximate Conversion Factors

To change	To	Multiply by	To change	To	Multiply by
inches	centimeters	2.540	ounce-inches	newton-meters	.007062
feet	meters	.305	centimeters	inches	.394
yards	meters	.914	meters	feet	3.280
miles	kilometers	1.609	meters	yards	1.094
square inches	square centimeters	6.451	kilometers	miles	.621
square feet	square meters	.093	square centimeters	square inches	.155
square yards	square meters	.836	square meters	square feet	10.764
square miles	square kilometers	2.590	square meters	square yards	1.196
acres	square hectometers	.405	square kilometers	square miles	.386
cubic feet	cubic meters	.028	square hectometers	acres	2.471
cubic yards	cubic meters	.765	cubic meters	cubic feet	35.315
fluid ounces	milliliters	29.573	cubic meters	cubic yards	1.308
pints	liters	.473	milliliters	fluid ounces	.034
quarts	liters	.946	liters	pints	2.113
gallons	liters	3.785	liters	quarts	1.057
ounces	grams	28.349	liters	gallons	.264
pounds	kilograms	.454	grams	ounces	.035
short tons	metric tons	.907	kilograms	pounds	2.205
pound-feet	newton-meters	1.356	metric tons	short tons	1.102
pound-inches	newton-meters	.11296			

Temperature (Exact)

°F Fahrenheit temperature 5/9 (after subtracting 32) Celsius temperature °C

